

Sewerage Impact Assessment

in support of

**Section 12A Application for Proposed Rezoning from
"Comprehensive Development Area" and "Green Belt" Zones
to "Residential (Group A)4" Zone and
to Amend the Notes of the Zone Applicable to the Site for
Proposed Residential Development and Social Welfare Facility
(Residential Care Home for the Elderly)
at Lot Nos. 398 RP and 2188 in D.D. 121, Tai Tao Tsuen,
Hung Shui Kiu, New Territories**

(HT 23121)

March 2026

Drainage Consultant:

何田顧問工程師有限公司
HO TIN & ASSOCIATES
CONSULTING ENGINEERS LIMITED



Prepared and approved by:	LEE Kwok Cheung <i>RPE(Civil, Geo., Env.)</i>
---------------------------	---

CONTENT

List of Abbreviations

1. Introduction
2. The Subject Site and Proposed Development
3. Existing Sewerage Conditions of the Subject Area
4. Proposed Sewerage Works
5. Design Assumptions and Criteria
6. Potential Sewerage Impacts
7. Conclusion and Recommendations

FIGURES

Figure S1	Site Location Plan
Figure S2	Details of the Existing 400mm diameter Sewerage Branch Drain in front of 'Uptown'
Figure S3	Proposed Sewerage Works
Figure S4	Proposed Stormwater Drainage Layout

APPENDICES

Appendix 1	Copies of the BD approval letter and relevant drawings of the original sewerage proposal
Appendix 2	Copies of the relevant document submitted in associated with the Drainage Plan to BD
Appendix 3	Hydraulic Analysis of Relevant Sewers

List of Abbreviations

ADWF	Average Dry Weather Flow
C.I.	Cast Iron
EPD	Environmental Protection Department
GESF	EPD's Report No. EPD/TP 1/05 - Guidelines for Estimating Sewage Flows for Sewage Infrastructure Planning
HTA	Ho Tin & Associates Consulting Engineers Limited
FMH / SM	Foul / Sewer Manhole
FTM / STM	Foul / Sewer Terminal Manhole
OZP	Outline Zoning Plan
PDWF	Peak Dry Weather Flow
SIA	Sewerage Impact Assessment
SM	Sewerage Manual Part 1 (DSD, 2013)

1. Introduction

- 1.1 Ho Tin & Associates Consulting Engineers Limited was appointed by the Client to prepare this sewerage impact assessment to support a Section 12A Application for proposed rezoning from "Comprehensive Development Area" and "Green Belt" Zones to "Residential (Group A)4" Zone and to amend the Notes of the Zone applicable to the site for Proposed Residential Development and Social Welfare Facility (Residential Care Home for the Elderly).
- 1.2 This report presents the SIA for the proposed development under this rezoning application.
- 1.3 The objectives of this SIA are to:-
- indicate any changes/increase in the sewage flow due to the proposed residential development under application;
 - assess any potential sewage impacts of the proposed development on the existing sewerage facilities; and
 - propose mitigation measures and sewerage improvement scheme, if necessary, to minimize any adverse sewage impact.
- 1.4 The scope of this SIA includes:-
- general site description;
 - identification of existing/planned sewerage facilities for the concerned area;
 - estimation of sewage flow of the proposed development;
 - SIA on the existing sewerage facilities due to the increased sewage flow of the proposed development; and
 - proposal of new sewerage facilities to cater for the proposed development if found necessary.

2. The Subject Site and Proposed Development

- 2.1 The subject site comprises of at Lot Nos. 398 RP and 2188 in D.D. 121, Tai Tao Tsuen, Hung Shui Kiu, New Territories. It has an area of about 2,138m² and is located on the southeastern side of the 'Uptown' residential development and is bounded by Fui Sha Wai South Road on the northeastern side. The subject site is currently zoned "Comprehensive Development Area" and "Green Belt" on the Approved Tong Yan San Tsuen Outline Zoning Plan No. S/YL-TYST/14 (the OZP). The site location is shown on **Figure S1**.
- 2.2 It is proposed to rezone the subject site to "Residential (Group A)4" Zone and to amend the Notes of the Zone applicable to the Site for proposed residential development and social welfare facility (Residential Care Home for the Elderly) in order to develop the subject site with the following parameters:

Parameter	Remark
Total number of units of residential development	72
Population of residential development (average 2.7 persons/flat)	195 persons
Gross floor area (GFA) of RCHE	6,961m ²

3. Existing Sewerage Conditions of the Subject Area

- 3.1 Drainage Plan including existing sewerage in the vicinity and proposed sewerage connection works of the former Proposed Residential Care Home for the Elderly at Lot No. 2188 in D.D. 121, Tai Tao Tsuen had been submitted and was approved by Buildings Department ("BD") on 3 November 2022 (hereunder called the "original sewerage proposal"). Copies of the BD approval letter and relevant drawings of the original sewerage proposal are enclosed in **Appendix 1** for reference.
- 3.2 It was proposed in the original sewerage proposal to connect the sewerage of the subject development via a proposed sewerage running underneath Fui Sha Wai South Road and the emergency vehicular access to the nearest public sewerage manhole at the westbound of Castle Peak Road in front of the Uptown Tower 1. The adopted no. of employee and peak sewage flow from Lot No. 2188 in D.D. 121 was 176 (based on a GFA of the RCHE = 5313m²) and 4.56l/s respectively under a Peaking Factor of 8 (total UFF = 0.280m³/day/employee).

4. Proposed Sewerage Works

- 4.1 The subject development now comprises of both Lot Nos. 398 RP and 2188 in D.D. 121. Its anticipated intake year is 2031. There is not much changes in the sewerage conditions of the subject area since the BD approving the Drainage Plan. Therefore, it is proposed to maintain adopting the original sewerage proposal which was designed and approved for the then proposed RCHE at Lot No. 2188 in D.D. 121, except the proposed sewerage is to be connected to an existing 400mm diameter sewer branch drain at the existing footpath in front of the adjacent residential development 'Uptown' (details of the existing sewer refer to **Figure S2**) instead of directly connected to the existing manhole FMH1036685 such that excavation at the carriageway of Castle Peak Road – Hung Shui Kiu can be avoided as shown in **Figure S3**.

5. Design Assumptions and Criteria

- 5.1 Design approach, assumptions and criteria adopted in the original sewerage proposal (included in the BD approved Drainage Plan) are considered still valid and acceptable, therefore they are continued to be adopted in this assessment. Copies of the relevant document submitted in associated with the Drainage Plan to BD is enclosed in **Appendix 2** for reference.

Parameter	Remark
Total number of units of residential development	72
Population of residential development (average 2.7 persons/flat)	195 persons
Gross floor area (GFA) of RCHE	6,961m ²
Bed spaces in the RCHE	450 nos.

3. Existing Sewerage Conditions of the Subject Area

- 3.1 Drainage Plan including existing sewerage in the vicinity and proposed sewerage connection works of the former Proposed Residential Care Home for the Elderly at Lot No. 2188 in D.D. 121, Tai Tao Tsuen had been submitted and was approved by Buildings Department ("BD") on 3 November 2022 (hereunder called the "original sewerage proposal"). Copies of the BD approval letter and relevant drawings of the original sewerage proposal are enclosed in **Appendix 1** for reference.
- 3.2 It was proposed in the original sewerage proposal to connect the sewerage of the subject development via a proposed sewerage running underneath Fui Sha Wai South Road and the emergency vehicular access to the nearest public sewerage manhole at the westbound of Castle Peak Road in front of the Uptown Tower 1. The adopted no. of employee and peak sewage flow from Lot No. 2188 in D.D. 121 was 176 (based on a GFA of the RCHE = 5313m²) and 4.56l/s respectively under a Peaking Factor of 8 (total UFF = 0.280m³/day/employee).

4. Proposed Sewerage Works

- 4.1 The subject development now comprises of both Lot Nos. 398 RP and 2188 in D.D. 121. Its anticipated intake year is 2031. There is not much changes in the sewerage conditions of the subject area since the BD approving the Drainage Plan. Therefore, it is proposed to maintain adopting the original sewerage proposal which was designed and approved for the then proposed RCHE at Lot No. 2188 in D.D. 121, except the proposed sewerage is to be connected to an existing 400mm diameter sewer branch drain at the existing footpath in front of the adjacent residential development 'Uptown' (details of the existing sewer refer to **Figure S2**) instead of directly connected to the existing manhole FMH1036685 such that excavation at the carriageway of Castle Peak Road – Hung Shui Kiu can be avoided as shown in **Figure S3**.

5. Design Assumptions and Criteria

- 5.1 Design approach, assumptions and criteria adopted in the original sewerage proposal (included in the BD approved Drainage Plan) are considered still valid and acceptable, therefore they are continued to be adopted in this assessment. Copies of the relevant document submitted in associated with the Drainage Plan to BD is enclosed in

Appendix 2 for reference.

5.2 The key relevant information in the original sewerage proposal are summarized as follows:

5.2.1 Design References –

- Guidelines for Estimating Sewage Flows for Sewage Infrastructure Planning (GESF), Environmental Protection Department
- Hong Kong Planning Standards and Guidelines (HKPSG), Planning Department
- Sewerage Manual (SM), Drainage Services Department
- Commercial and Industrial Floor Space Utilization Survey (CIFSUS), Planning Department
- Sewerage Records retrieved from GeoInfo Map

5.2.2 Unit Flow Factors (UFF) –

- For domestic flows (for domestic sewage flow estimation of residential population in the sewerage catchment adjacent to the subject development, the proposed residential and RCHE development)

Residential Type	Unit Flow Factors (m ³ /person/day)
Private R2	0.270
Institutional and special class	0.190

Referenced from Table T-1 in GESF

- For commercial flows (for sewage flow estimation of employed population of the proposed RCHE)

Commercial Type	Unit Flow Factors (m ³ /person/day)
Commercial Employee	0.080
Commercial Activities	
(a) Specific trades:	
J11 – Community, Social and Personal Services	0.200*
Total UFF	0.280

Referenced from Table T-2 in GESF

* UFF for J11 accounts for flows of customers and tenants

5.2.3 Peaking Factors –

Population Range**	Peaking Factor (including stormwater allowance)*** for Facility with Existing Upstream Sewerage
(a) For sewers	
< 1,000	8
1,000 – 5,000	6

Referenced from Table T-5 in GESF

** Contributing Population = Calculated total average flow (m³/day)/0.27(m³/person/day)

*** To be conservative

5.2.4 Catchment Inflow Factor (P_{CIF}) - 1.00 for Yuen Long Catchment as recommended in Table T-4 in the GESF is applied to the existing sewerage system to indicate the potential net overall ingress of water or waste water to the sewerage system in the assessment.

5.2.5 Hydraulic Analysis –

- Colebrook-White equation is applied for pipe hydraulic analysis.
- The design roughness coefficients (k_s) for all pipes is conservatively taken as 3.0mm (slimed sewer, clayware, under poor condition).
- For small diameter sewer of diameter less than 300mm, the flow velocity of at least 0.7m/s shall occur daily, or that a gradient of at least 1:DN (i.e. nominal diameter of the sewer in mm) is provided, provided that a flow of 2 times of Average Dry Weather Flow (ADWF) is assumed to occur at least once daily. For larger diameter sewers of diameter up to 900mm, a self-cleansing velocity of 1.0m/s in full pipe condition shall be achieved. The maximum flow velocity at peak flow shall be 3m/s.

5.2.6 Sewage Flow Estimation of the Original Sewerage Proposal –

- the maximum number of employees in the proposed RCHE is estimated based on the worker density with reference to the PlanD's CIFSUS and the maximum GFA of the RCHE development in the following table:

GFA (m ²)	Industry Group [#]	Worker Density (No. of Employee/100m ² GFA) [#]	No. of Employee
5,313	Community, Social & Personal Services	3.3	176

[#]Referenced from Figure 9 – "Worker Density by Industry Group" of the PlanD's CIFSUS

- the sewage flow estimation of the RCHE development is illustrated in the following table:

No. of Employee	UFF (m ³ /day/person)	ADWF (m ³ /day)	Peaking Factor	Peak Flow (l/s)
176	0.28	49.28	8	4.56

- the sewage flow estimation of the private residential development of Uptown and the Woodside (for assessing the existing DN375 sewer along Castle Peak Road) is illustrated in the following table:

Contributing Sewerage Catchment	No. of Flat	No. of Residents	UFF (m ³ /day/person)	ADWF (m ³ /day)	Peaking Factor	Peak Flow (l/s)
Uptown	734	2,055	0.27	554.90	6	38.54
The Woodside	98	274		74.09	8	6.86

5.3 Sewage Flow Estimation of the Subject Development –

- the maximum number of employees in the proposed RCHE part is estimated in the following table:

GFA (m ²)	Industry Group [#]	Worker Density (No. of Employee/100m ² GFA) [#]	No. of Employee
6,961	Community, Social & Personal Services	3.3	230

- the sewage flow estimation of the proposed RCHE part is evaluated in the following table:

No. of Employee or Bed Space	UFF (m ³ /day/person or bed space)	ADWF (m ³ /day)	Peaking Factor	Peak Flow (l/s)
230	0.28	64.40	8	5.97
450	0.19	85.50	8	7.92
			Total =	13.89

- the sewage flow estimation of the residential development part of the subject development is referenced to Private R2 Residential Type development as follows:

No. of Residents	UFF (m ³ /day/person)	ADWF (m ³ /day)	Peaking Factor	Peak Flow (l/s)
195	0.27	52.65	8	4.88

- the total sewage flow estimation (under a Peaking Factor of 8) of the subject development is therefore as follows:

Contributing Part	Peak Flow (l/s)
RCHE part	13.89
Residential Development part	4.88
Total	18.77

6. Potential Sewerage Impacts

- 6.1 Sewerage of the subject area is assessed to identify any sewers with inadequate capacity arising from the subject development as included in **Appendix 3**. Internal sewerage system of the subject development will be designed and submitted to BD for approval at the later detailed design stage.
- 6.2 Results of the assessment of the existing DN400 branch sewer and DN375 sewers at Castle Peak Road – Hung Shui Kiu are summarized in the following table:

Upstream Manhole ID	Downstream Manhole ID	Sewer Length (m)	Peak Flow* (l/s)	Sewer Hydraulic Capacity (l/s)	% of Peak Flow over Sewer Hydraulic Capacity
Feature FWD1045721 (400mm dia. drain IL +8.585)	FMH1036685 (IL +8.502)	13.31	46.678	211.663	28%
FMH1036685	FMH1043120	41.7	46.678	77.904	75%
FMH1043120	FMH1036686	3.2	49.250	154.319	40%
FMH1036686	FMH1036687	19.1	49.250	96.377	64%
FMH1036687	FMH1036688	41.7	49.250	199.071	31%
FMH1036688	FMH1036689	3.2	51.823	178.237	36%
FMH1036689	FMH1036690	41.2	51.823	85.886	75%
FMH1036690	FMH1036691	39.2	51.823	91.664	70%

* Peaking Factor = 6 since total population >1,000 and <5,000

7. Conclusion and Recommendations

- 7.1 The sewage flow generated from the subject development will be collected by an internal sewerage system and conveyed into a proposed terminal sewerage manhole from which a new sewer will be laid to connect to the existing 400mm diameter branch sewer drain at the footpath in front of 'Uptown' encroaching upon Castle Peak Road – Hung Shui Kiu.
- 7.2 From the hydraulic capacity checking of the existing sewers at Castle Peak Road – Hung Shui Kiu serving the subject area, it reveals that the existing sewers are capable to collect the sewage flow generated from the subject development. It has been assessed that even with the subject development, only about maximum 75% capacity of the existing 375mm diameter public sewer at the immediate downstream at Castle Peak Road – Hung Shui Kiu will be utilized. The existing sewer system will still have spare capacity to receive the sewage flow generated from other developments in the area when necessary.
- 7.3 Detailed design of the proposed sewerage connecting works and the internal sewerage system will be submitted to the Building Authority who will circulate the submission to all relevant departments by means of central processing mechanism for comment, for approval prior to commencement of the construction works.
- 7.4 In view of the above, the subject development would have no adverse sewerage impact on the local existing sewerage system.

H:\23121_Lot 2188\DRAWING\23121_FIGURE S1 S3.dwg, 2/9/2025 15:44:55

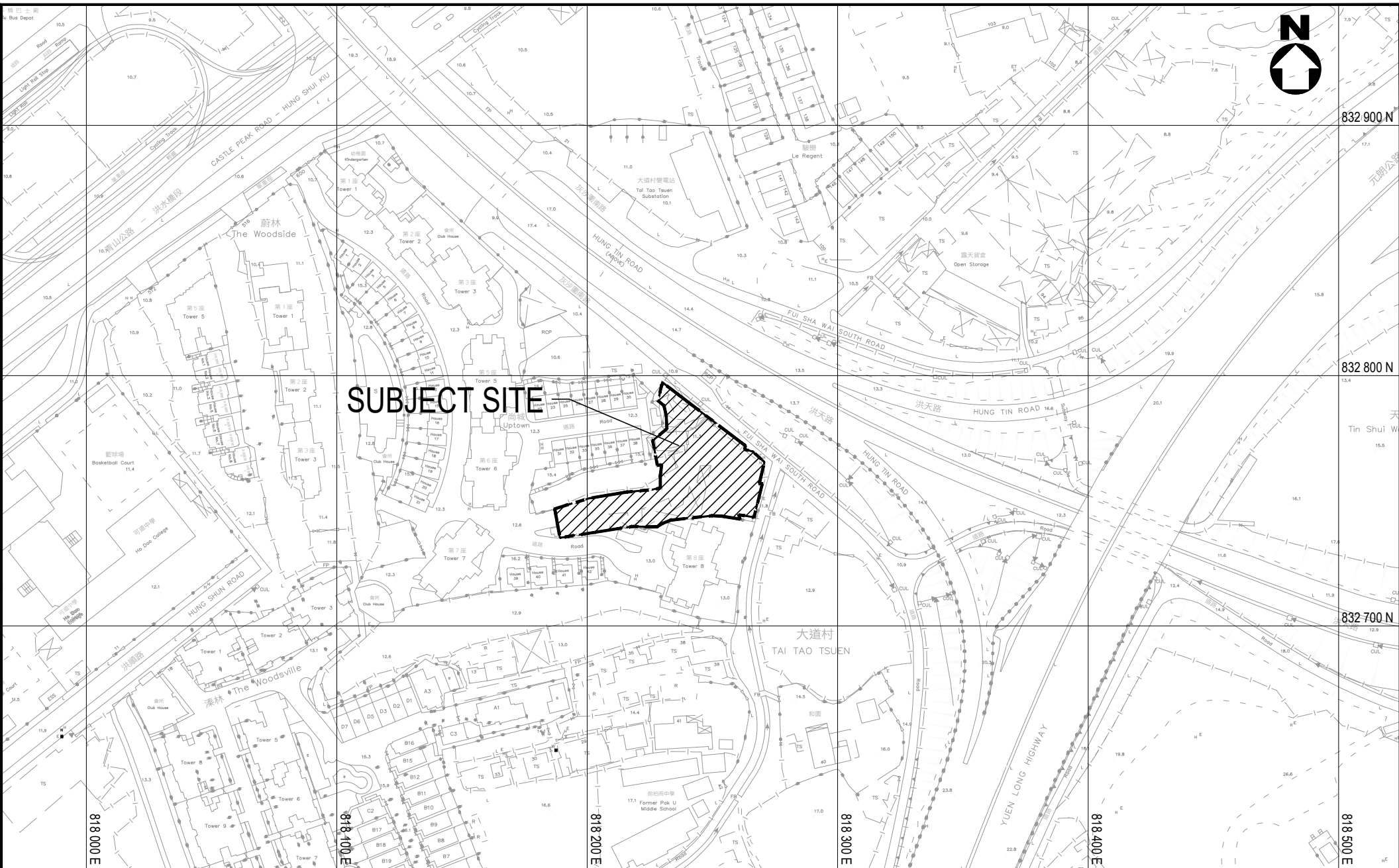

PROJECT	
TITLE	LOCATION PLAN

何田顧問工程師有限公司 HO TIN & ASSOCIATES CONSULTING ENGINEERS LIMITED	
SCALE	DRAWING No.
1 : 2000(A4)	FIGURE S1

LAND AND PROPERTY > DRAINAGE PIPES AND MANHOLES

x: 818085, y: 832884

Feature Number

FWD1045721

Shape

Circular

Diameter (mm)

400

Upstream Invert Level (mPD)

8.585

Downstream Invert Level (mPD)

8.502

Legend

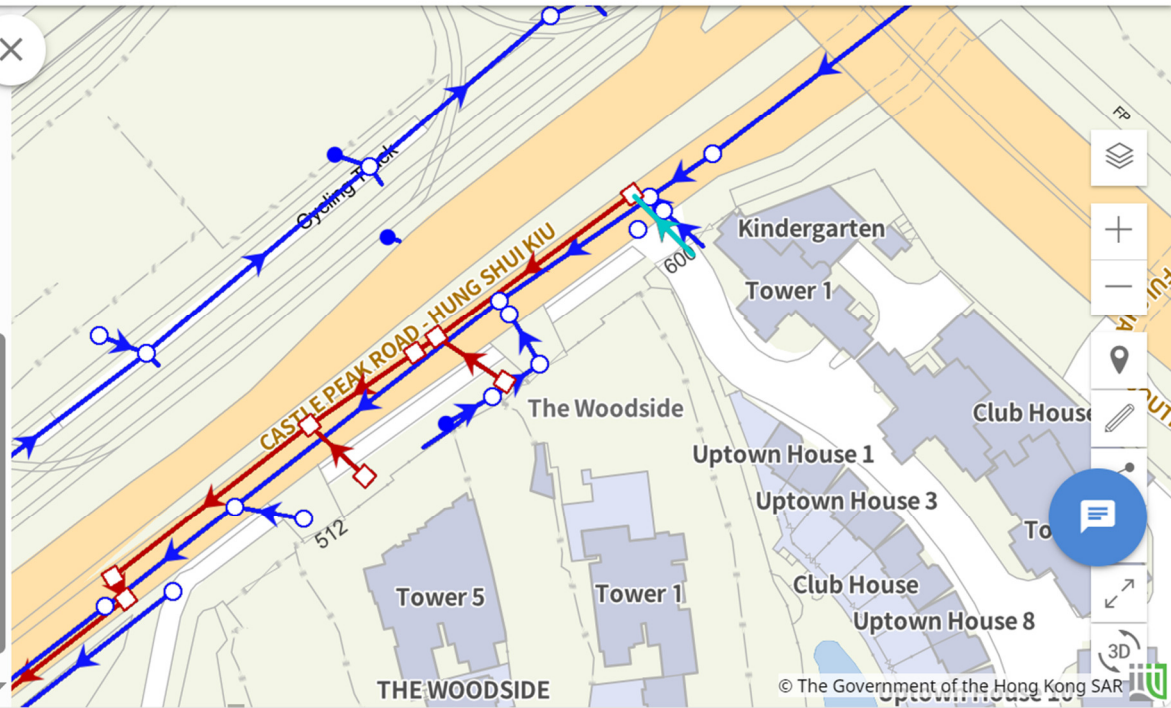
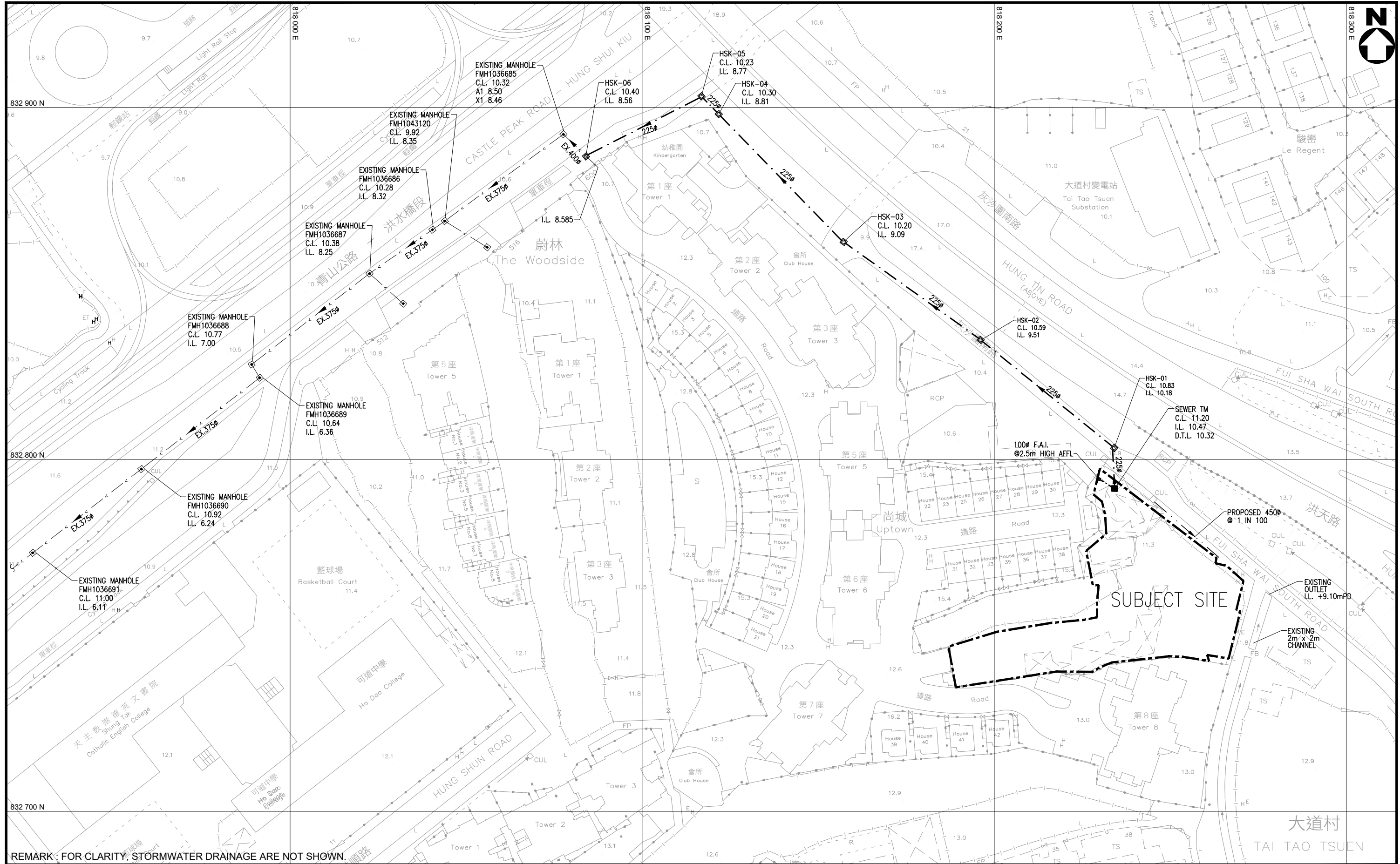

Figure S2 – Details of the Existing Sewer Branch Drain in front of ‘Uptown’



REMARK: FOR CLARITY, STORMWATER DRAINAGE ARE NOT SHOWN.

LEGEND:	
	THE SUBJECT SITE BOUNDARY
	PROPOSED SEWER
	EXISTING PUBLIC SEWER
	PROPOSED SEWER TERMINAL MANHOLE (INTERNAL SEWERAGE WORK WILL BE SUBMITTED SEPARATELY)
	PROPOSED SEWER MANHOLE
	EXISTING PUBLIC SEWER MANHOLE

PROJECT	何田顧問工程師有限公司 HO TIN & ASSOCIATES CONSULTING ENGINEERS LIMITED
TITLE	PROPOSED SEWERAGE WORKS
SCALE	1 : 1000(A3)
DRAWING No.	FIGURE S3

H:\23121_Lot2188\DRAWING\23121_FIGURE S1 S3.dwg, 2/9/2025 15:46:25

H:\23121_Lot 2188\DRAWING\23121_FIGURE D1 D3 & D4.dwg, 26/8/2025 17:16:24

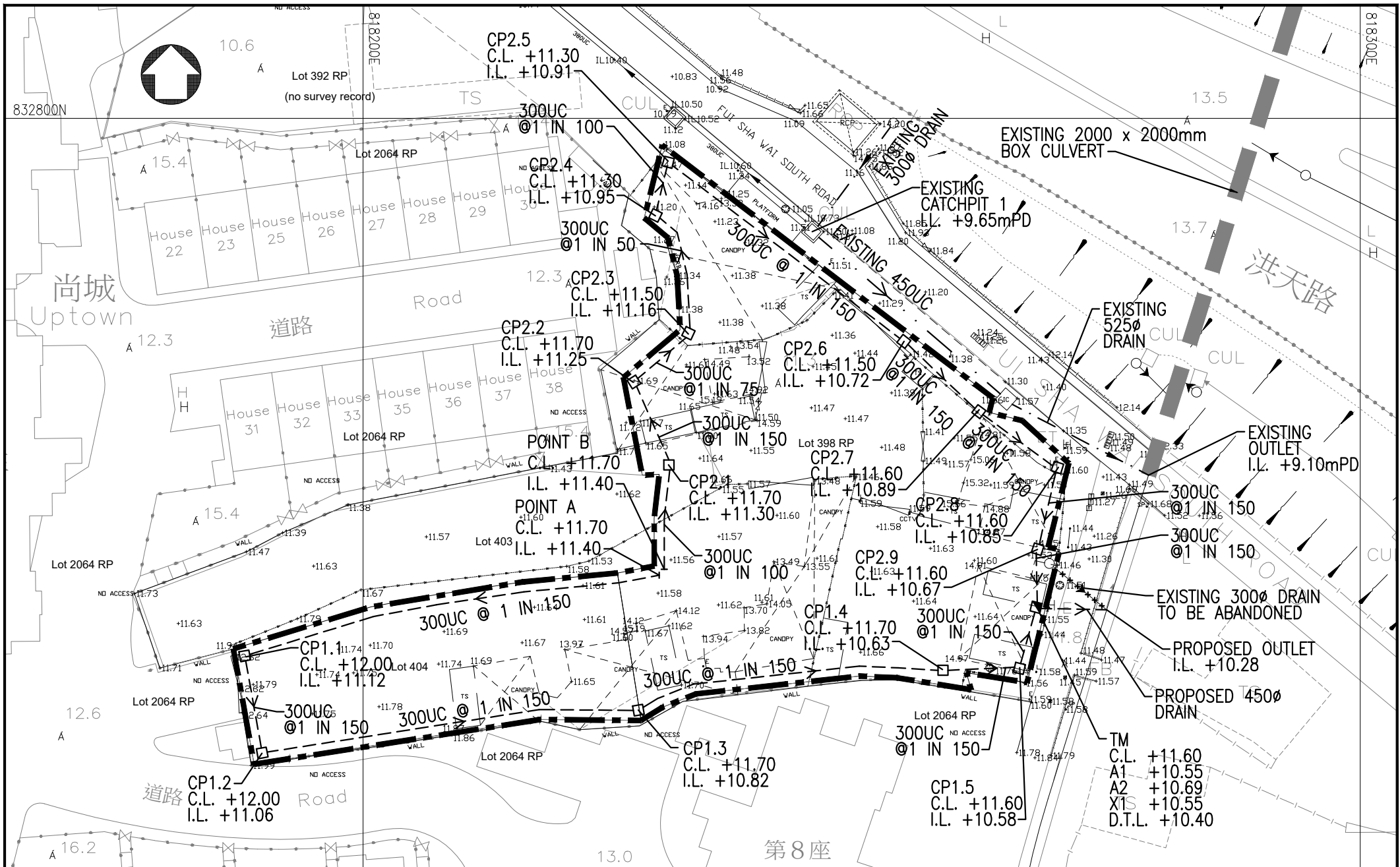

LEGEND:					
	THE SUBJECT SITE		PROPOSED TERMINAL MANHOLE		EXISTING DRAIN
	PROPOSED U-CHANNEL		EXISTING UC		EXISTING STORMWATER DRAINAGE
	PROPOSED CATCH PIT				

PROJECT	
TITLE	PROPOSED STORMWATER DRAINAGE LAYOUT

何田顧問工程師有限公司 HO TIN & ASSOCIATES CONSULTING ENGINEERS LIMITED	
SCALE	DRAWING No.
1 : 500 - A4	FIGURE D4

Appendix 1 - Copies of the BD approval letter and relevant drawings of the original sewerage proposal

Lam Wan Fung Bernard Vincent

3 November 2022

RECEIVED
04 NOV 2022

220

BY:.....

(51)

Dear Sir,

Tai Tao Tsuen, Hung Shui Kiu, Yuen Long, N.T.
- D.D. 121 Lot 2188

I refer to your application received on 8 September 2022 with complete substitution of drawings on 31 October 2022 for approval of proposals in respect of Drainage.

2. Your submission of plans has been checked under the curtailed check system announced in Practice Note for Authorized Persons, Registered Structural Engineers and Registered Geotechnical Engineers (PNAP) ADM-19 and refined according to the Circular letter issued on 30 October 2013. On this basis, I am satisfied that your submission is fundamentally acceptable and may be approved.

3. You are reminded that under the refined curtailed check system, the items of fundamental issues have been curtailed and only a specified percentage of the drainage proposal has been randomly checked. Hence, notwithstanding that there may be fundamental issues and non-fundamental issues, they will not be raised as reasons for disapproving a submission. However, I expect that all contraventions of the Buildings Ordinance (BO) and its subsidiary legislation are rectified as and when they are discovered and in any event, before completion of the works is certified. In this connection, I ask you to note that the Building Authority attaches great importance to the proper assumption of duties and responsibilities by authorized persons and registered structural engineers and registered geotechnical engineers.

4. In accordance with the provisions of regulation 30(1) of the Building (Administration) Regulations, this is to notify that the Drainage plans submitted with your application received on 8 September 2022 with complete substitution of drawings on 31 October 2022 are hereby approved. One set of the said plans, on which I have signified my approval, is enclosed. Your client has been sent a copy of this letter but I would request that you ensure that the contents are understood by him.

5. This approval should not be deemed to confer any title to land or to act as a waiver of any term in any lease or licence. This approval does **NOT** authorize the commencement or the carrying out of any works shown in the approved plans. Section 14(2) of the BO refers.

6. Approval of the subject drainage plans covers the proposed provisions and layouts of drainage items only. Building layouts as shown are for reference only. Those shown on approved building plans shall prevail.

7. A Form BD 106 is attached herewith.

/8...

SL 9(12/2015) (T-D ra)

8. The Chief Engineer/Mainland North of Drainage Services Department (CE/MN of DSD) (contact officer: Jeff C W TSE at tel: 2300 1627) has comments (attached in Appendix I) which had been conveyed to your representative on 30 September 2022 via email. It was noted that your representative had responded her comments on 24 October 2022 and CE/MN of DSD had no further comment to your submission on 25 October 2022. Since you have amended the subject plans according to CE/MN of DSD's comments prior to this approval, you should forward a copy of the relevant approved drainage plans to the Department for record.

9. The Chief Highway Engineer/NT West of Highways Department (CHE/NTW, HyD) (contact officer: Ben CK CHAN at tel: 2762 4965) has comments in Appendix II attached.

10. Chief Geotechnical Engineer / Mainland West, Geotechnical Engineering Office, Civil Engineering and Development Department (GEO, CEDD) (contact officer: Sylvia S W CHIK at tel: 2762 5222) has no geotechnical objection to the approval of the plans with reminder to AP/RSE/RGE that excavation and lateral support plans taking into consideration the requirements of B(A)R8(1)(bc) shall be submitted to BD for approval prior to consent application for commencement of the works, if found necessary.

11. The Project Manager (West), Civil Engineering and Development Department (PM(W), CEDD) (contact officer: Odilia Y Y NG at tel: 2158 5617) has no comment on your submission.

12. Your plans have also been referred to the District Lands Officer/Yuen Long (DLO/YL) for comment which will be issued to you directly.

13. This records that you have completely substituted drawings [drawing nos.: HT 21016/DD/001 to 005] on 31 October 2022. Please furnish a copy of this approved plan to relevant departments for record and further comments, if any. Your attention is again drawn to section 4(3) of the BO.

14. If you have any queries, please contact our Mr. Amen YUNG at 2626 1434.

Yours faithfully,

c.c. **Right Fortune Investment Limited**

[By Fax Only: 2674 2301]

**CE/MN, DSD
CHE/NTW, HyD
GEO, CEDD
PM/NTW, CEDD
DLO/YL**

[By Fax Only: 2770 4761]

[By Fax Only: 2714 5228]

[By Fax Only: 2194 0165]

[By Fax Only: 2693 2918]

[By Fax Only: 2473 3134]

(**CHENG Hang-on, Colin**)
Senior Building Surveyor
for Building Authority

Our Ref. : (14) in BD 4/9045/21

Address : Tai Tao Tsuen, Hung Shui Kiu, Yuen Long, New Territories - D.D. 121 Lot 2188

Appendix I

CE/MN of DSD has the following comments, and it was noted that your representative had responded her comments on 24 October 2022 and CE/MN of DSD had no further comment to your submission on 25 October 2022.

The submitted drawings have been examined and my comments are as follows:

- (a) Cover level, invert level and manhole type of the proposed stormwater terminal manhole TM should be provided for comments.
 - (b) Please indicate the ID nos. of the existing government manholes (i.e. Existing Catchpit 1 and Existing Catchpit 2) on the drainage layout plan.
 - (c) The proposed connection pipes should have 300mm clearance as far as possible from any existing drains or other proposed connection pipes.
 - (d) According to the attached SIA Report (ver. March 2018), it is noted that the proposed alignment of the sewerage connection is not updated and have difference with the one as shown in drawing no. HT 21016/DD/001. Please check.
2. In addition, the A.P. is reminded of the following general comments:
- (a) This Department will only take over those public drainage facilities constructed on government land and located downstream of the terminal manhole.
 - (b) DSD shall not maintain all such drains and manholes proposed to be laid within private lots adjacent to the development. The A.P. has to confirm the future maintenance responsibilities of such drains and manholes.
 - (c) Any alternation/demolition/modification/removal works made upon existing DSD's facilities should have consent and agreement from this Division prior to commencement of works and should ensure that the proposed works would not adversely affect the structural integrity of any existing drainage/sewerage system.
 - (d) The proposed drainage works, whether within or outside the lot boundary, should be constructed and maintained by the lot owner at their own expense. For works to be undertaken outside the boundary, prior consent and agreement from DLO/YL and/or relevant private lot owners should be sought.
 - (e) All proposed drainage connection works should be carried out by the developer in accordance with DSD Standard Drawings at the developer's cost. The A.P. is reminded to submit the HBP1 application form together with a cheque to DSD for a technical audit of the completed connection works. All drainage/sewerage works to be handed over to this Department shall conform to the requirements stipulated in Stormwater Drainage Manual, Sewerage Manual, DSD Standard Drawings, DSD Technical Circulars, Practice Notes and Guidelines, etc.

The A.P. is required to submit the declaration form (form no.: HBP1_CC) before the inspection and to provide certified as-built drainage plans to DSD for record.

For connection works involving special designs, features and/or materials such as couplings, rising mains, welded joints or the like, 2-staged technical audits would be required prior to backfilling and after completion of the connection works.

Our Ref. : (14) in BD 4/9045/21

Address : Tai Tao Tsuen, Hung Shui Kiu, Yuen Long, New Territories - D.D. 121 Lot 2188

Appendix I [Cont'd]

- (f) It is the developer's responsibility to identify/locate the existing government sewers and stormwater drains to which drainage connections from his site are to be proposed. The A.P. should verify the existence of any drains/sewers/utilities and also their exact locations, levels and alignments on site in order to ascertain the positions and levels of the proposed manholes and the associated connection works. The A.P. should also verify that the existing government drains/sewer, to which connections are proposed, are in normal working conditions and capable for taking the discharge from the site. Besides, for any excavation works over or in close vicinity to existing government drains/sewers, the A.P. should notify DSD in writing at least 14 working days before backfilling the excavation works and arrange joint site inspection with DSD prior to covering up.

The A.P. is also reminded that any person wilfully, except with the permission in writing of the Authority, or negligently damages, alters, disconnects or otherwise interferes with any public sewer or drain or any connection therewith, shall be guilty of an offence under Section 6 of Public Health and Municipal Services Ordinance (Cap 132).

- (g) The A.P. is required to liaise with relevant utility undertakers to obtain the latest records, plans and alignments of their utilities in order to ensure the feasibility of the proposed drainage works. The A.P. is also required to excavate inspection pits and conduct utility detection to verify the alignments of utilities shown in such utility records if considered necessary.
- (h) The A.P. is required to ensure that no construction debris, silt and sediments, or cementitious materials will be discharged to or deposited inside the public drains or sewers from the site. The A.P. shall monitor the internal conditions of the existing public drains/sewers running adjacent to the site with CCTV surveys (or other agreed alternatives) prior to commencement and upon completion of his/her works to our satisfaction. The A.P. shall also provide details of all discharge point(s) in the discharge licence approved by EPD and make necessary arrangement/agreement with this Department for the scope of CCTV surveys (or other agreed alternatives). Nevertheless, such CCTV surveys (or other agreed alternatives) serve no intention to relieve the A.P.'s liabilities on other drains/sewers that are not included in these surveys. Any pipe blockage or damage arising from the construction works shall be made good at the cost of the developer and to our satisfaction.
- (i) Under the Water Pollution Control Ordinance (Cap 358), discharge of wastewater into stormwater drains is not permitted. The A.P. shall ensure that the proposed sewerage works shall convey all wastewater, including but not limited to those wastes generated by the domestic use of toilets, water closets, baths, showers, sinks, basins and other sanitary and kitchen fittings, through the sewage terminal manhole(s) to the public sewers. Besides, to ensure the sustainability of the public sewerage network, the A.P. shall ensure that the surface runoff within the development site will be collected and discharged via a stormwater drainage system and not be drained to the public sewerage network.

Our Ref. : (14) in BD 4/9045/21

Address : Tai Tao Tsuen, Hung Shui Kiu, Yuen Long, New Territories - D.D. 121 Lot 2188

Appendix II

The CHE/NTW, HyD has the following comments:

I refer to your referenced memo and have the following comments from the highways maintenance point of view:

- (a) The sewerage connection is outside the purview of this Office;
- (b) It is noted that the stormwater connection is made to DSD catchpit SCH1013920. I have no comment on this arrangement. Please be reminded that the existing 375 UC just next to the above catchpit falling toward NW direction is maintained by this Office, the AP and his contractor shall ensure the connection is not made to this existing 375 UC;
- (c) The drainage designs should be subject to the comment and approval of CE/MN, DSD. The AP shall also clarify with DSD for the maintenance responsibility of the drainage system;
- (d) A minimum cover of 900mm and 450mm should be provided for drainage pipes under carriageway and footpath respectively;
- (e) The AP should ensure that the existing drainage system has sufficient capacity to carry the discharge from the proposed development;
- (f) The AP should ascertain the alignment and level of existing utility services in the vicinity prior to the commencement of drainage works;
- (g) No runoff contaminated with cement/grout/sand/silt shall be discharged to public road drains. Adequate drainage measures including interception channels should be provided to prevent runoff from the lot from flowing into public road drains;
- (h) Comments from Lighting Division of this Department should be sought if public lightings are affected;
- (i) The AP should exercise due care to avoid damaging public footpaths/roads, and other highway structures/facilities arising from his drainage works. Any damages should be immediately repaired to highway standards and my satisfaction by the developer at his own expense; and
- (j) Should excavation works on public roads or footpaths be required, an Excavation Permit should be obtained from this Office prior to commencement of excavation works. Should excavation works on unallocated Government Land be required, an Excavation Permit should be obtained from DLO/YL direct.

BUILDING AUTHORITY OF HONG KONG
Form BD 106
BUILDINGS ORDINANCE
(Chapter 123)
Section 42

Permit under Section 42

Permit No. NT516/2022/MOD

Our Ref. No. (15) in BD 4/9045/21

To : Right Fortune Investment Limited
c/o Lam Wan Fung Bernard Vincent

Date 3 November 2022

In exercise of the powers vested in me by section 42 of the Buildings Ordinance, I hereby grant modification of and/or exemption from the provisions of:-

- (A) **Regulation 44(1) of Building (Standards of Sanitary Fitments, Plumbing, Drainage Works & Latrines) Regulations [B(SSFPDW&L)R]** to permit the use of ductile iron pips for the covered drains; and
- (B) **Regulation 56(7) of B(SSFPDW&L)R** to permit the use of ductile iron cover for manhole;

in respect of the proposed building works at (No. and name of street and locality) Tai Tao Tsuen, Hung Shui Kiu, Yuen Long, N.T. on (lot no.) D.D. 121 Lot 2188 :-

2. This permit is granted subject to the following conditions:-

- (a) The said works are to be carried out in accordance with the plans approved on 3 November 2022 under our Ref. No. BD 4/9045/21.
- (b) The conditions imposed in this paragraph are to be incorporated in the subsequent amendment plans for approval before the application for an occupation permit is submitted.
- (c) A checklist of valid Forms BD106 is to be submitted at the time of the submission of the application of occupation permit upon completion.
- (d) This permit will expire on 2 November 2024 if the consent to commence the above works is not obtained on or before the specified date or where such consent has been obtained but is deemed to be revoked under section 20(1) of the Buildings Ordinance after the specified date.

-- End --

c.c. CO/SM
BD GR/OA/118

(CHENG Hang-on, Colin)
Senior Building Surveyor
for Building Authority

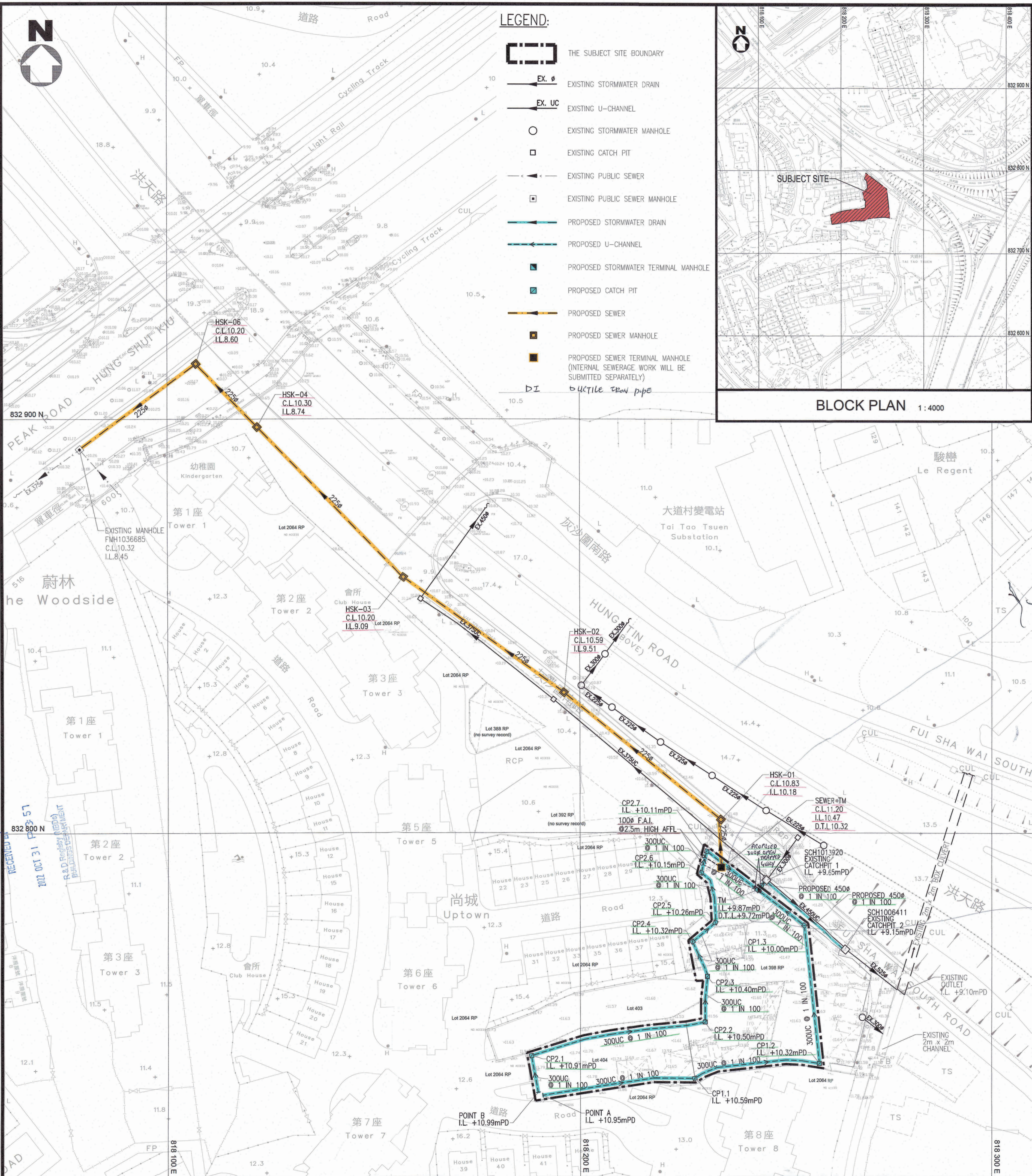

GENERAL NOTES:

- ALL ALIGNMENTS OF THE EXISTING DRAINAGE/SEWERAGE SYSTEM AS SHOWN ON THE DRAWINGS ARE INDICATIVE ONLY. THE EXACT LEVEL AND LOCATION OF EXISTING DRAINAGE SYSTEM SHALL BE DETERMINED ON SITE.
- ALL DIMENSIONS ARE IN MM. ALL LEVELS ARE IN MPD UNLESS NOTED OTHERWISE.
- ALL MATERIAL AND WORKMANSHIP REQUIREMENTS SHALL BE IN ACCORDANCE WITH APPROVED MATERIALS SUBMISSIONS, TESTING AND WORKMANSHIP REQUIREMENTS OF THE GENERAL SPECIFICATION FOR CIVIL ENGINEERING WORKS (LATEST EDITION) AND RELEVANT SPECIFICATION.
- REINSTATEMENT OF EXISTING CONCRETE CARRIAGEWAY SHALL BE IN ACCORDANCE WITH HYD STANDARD DRAWING NOS. H1124 AND H1125 (LATEST VERSION) UNLESS OTHERWISE SPECIFIED. (FOR DSD & HYD REFERENCE, AND NOT FOR BD APPROVAL)
- REINSTATEMENT OF EXISTING BITUMINOUS CARRIAGEWAY SHALL BE IN ACCORDANCE WITH HYD STANDARD DRAWING NOS. H1129 AND H1130 (LATEST VERSION) UNLESS OTHERWISE SPECIFIED. (FOR DSD & HYD REFERENCE, AND NOT FOR BD APPROVAL)
- REINSTATEMENT OF EXISTING PAVED AREA SHALL BE IN ACCORDANCE WITH HYD STANDARD DRAWING NOS. H1127 AND H1128 (LATEST VERSION) UNLESS OTHERWISE SPECIFIED. (FOR DSD & HYD REFERENCE, AND NOT FOR BD APPROVAL)
- PE PIPES AND FITTINGS SHALL COMPLY WITH BS EN 12201-2 AND BS EN 12201-3 RESPECTIVELY, AND HAVE A MATERIAL DESIGNATION OF PE 100.
- THE LOCATIONS OF THE PROPOSED MANHOLES AND DRAINAGE/SEWERAGE ALIGNMENTS SHOWN ON DRAWINGS ARE APPROXIMATE ONLY. THE EXACT LOCATIONS AND ALIGNMENTS AND MANHOLES ARE TO BE DETERMINED ON SITE.
- PIPE BEDDING SHALL REFER TO DSD STANDARD DRAWINGS DS1048B AND DS1049B UNLESS OTHERWISE SPECIFIED. (FOR DSD & HYD REFERENCE, AND NOT FOR BD APPROVAL)
- ALL MATERIALS FOR PIPEWORK SHALL BE IN ACCORDANCE WITH CEDD'S GENERAL SPECIFICATION FOR CIVIL ENGINEERING WORKS AND DSD'S STORMWATER DRAWING MANUAL.
- FLEXIBLE JOINTS FOR PIPES WITH CONCRETE BEDDING OR SURROUND ARE TO CONFORM WITH THE REQUIREMENTS OF DSD STANDARD DRAWING DS 1050B. (FOR DSD & HYD REFERENCE, AND NOT FOR BD APPROVAL)
- THE GROUND LEVEL SHOWN ON MANHOLE SCHEDULE AND LONGITUDINAL PROFILE IS APPROXIMATE ONLY.
- FOR ALL PROPOSED CONNECTION INTO THE EXISTING MANHOLES AND DRAINS, THE EXACT LOCATION OF CONNECTION POINT AND INVERT LEVELS SHALL BE VERIFIED ON SITE PRIOR TO CONSTRUCTION.
- STEP IRONS SHALL FOLLOW THE STANDARD AS PER DSD STANDARD DRAWING NO. DS 1043B.
- PRECAST CONCRETE PIPES AND FITTINGS SHALL COMPLY WITH BS EN 1916 AND BS 5911-PART 1 AND SHALL HAVE FLEXIBLE SPIGOT AND SOCKET JOINTS.
- FULL PIPE LENGTHS ARE TO BE INSTALLED AS FAR AS POSSIBLE.
- CONCRETE GRADE TO MANHOLES SHALL BE AS SHOWN ON DSD STANDARD DRAWINGS AND AS DESCRIBED ON THE DRAWINGS FOR SPECIAL MANHOLES. ALL CONCRETE IN CONTACT WITH THE GROUND SHALL BE LAID ON 75MM THICK BLINDING CONCRETE OF GRADE 10/20 UNLESS OTHERWISE STATED. (FOR DSD & HYD REFERENCE, AND NOT FOR BD APPROVAL)
- ALL EXISTING DRAINAGE/SEWERAGE FACILITIES SHALL ONLY BE ABANDONED / DEMOLISHED AFTER THE COMPLETION OF THE ASSOCIATED DIVERSION WORKS TO THE SATISFACTION OF DSD. IN ADVANCE, APPROVAL BY DSD SHALL BE SOUGHT PRIOR TO ANY ABANDONMENT OR DEMOLITION.
- ALL EXISTING DRAINS/SEWERS TO BE ABANDONED SHALL BE FILLED WITH CEMENT GROUT. DETAILS AND MATERIALS SHALL BE SUBMITTED TO DSD FOR APPROVAL.
- ALL DIMENSIONS SHOULD BE VERIFIED ON SITE PRIOR TO COMMENCEMENT OF CONSTRUCTION.
- ALL EXPOSED CONCRETE EDGES TO HAVE 25x25 CHAMFER UNLESS OTHERWISE STATED.
- ALL STRUCTURAL DESIGN, CALCULATIONS, DETAILS FOR DRAINAGE WORKS WITHIN SITE BOUNDARY ARE UNDER SEPARATE SUBMISSION.
- TESTING OF DRAINAGE WORKS WITHIN SITE BOUNDARY SHALL BE IN COMPLIANCE WITH PNAP APP-58.
- DI PIPES AND FITTINGS SHALL COMPLY WITH BS EN 12201-2 AND BS EN 12201-3. PIPES AND FITTINGS SHALL BE LINED INTERNALLY WITH CEMENT MORTAR AND SHALL BE COATED EXTERNALLY WITH BITUMINOUS COATING.

EXTERNAL DRAINAGE AND SEWERAGE NOTES:

- REFER TO HO TIN'S DRAINAGE PROPOSAL OF DRAINAGE AND SEWERAGE SYSTEM FOR THE DESIGN CRITERIA AND CALCULATIONS.
- DESIGN OF THE EXTERNAL DRAINAGE AND SEWERAGE SYSTEMS IS CONDUCTED WITH REFERENCE TO THE REQUIREMENTS SET OUT UNDER THE FOLLOWING DOCUMENTS:
 - STORMWATER DRAINAGE MANUAL (FIFTH EDITION, JANUARY 2018).
 - SEWERAGE MANUAL PART 1 (THIRD EDITION, MAY 2013).
 - CIVIL ENGINEERING AND DEVELOPMENT DEPARTMENT (CEDD) GENERAL SPECIFICATION FOR CIVIL ENGINEERING WORKS VOLUME 1 AND VOLUME 2 (2020 EDITION).

TRAPPED GULLY SCHEDULE (STORMWATER DRAINAGE SYSTEM)

DISCHARGE PIPE SIZE (mm)	L	W	D (mm)	GRATING SIZE	COVER SIZE
300Ø	1200	1200	740	600x600	800x800

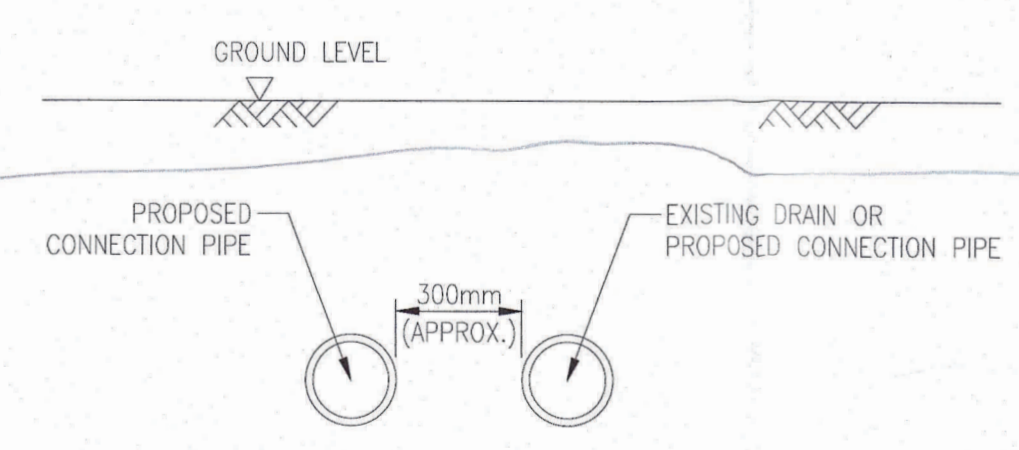
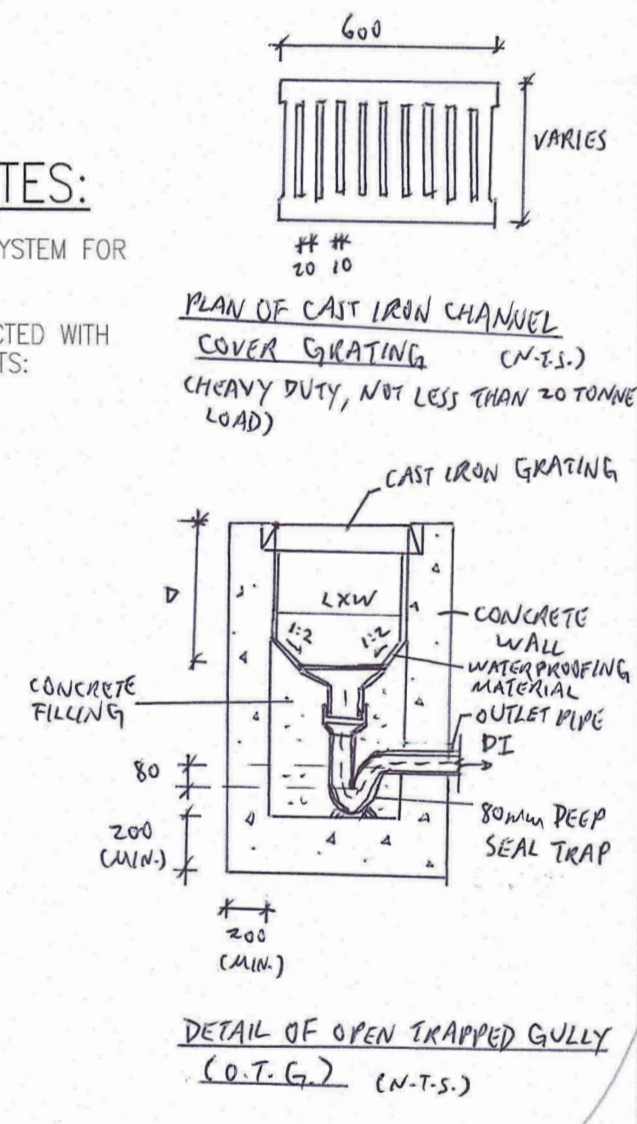

TYPICAL CLEARANCE BETWEEN CONNECTION PIPES
(N.T.S.)
(FOR DSD REFERENCE)

B.D. REF.

F.S.D. REF.

Do not scale drawing

Figured dimensions are to be taken in preference to scaled dimensions in all cases.

Read this drawing in conjunction with general architectural plans, structural plans and other related drawings. Before commencing work, the full extent and exact nature of the works shown on this drawing shall be ascertained and all dimensions verified with site measurements. Any discrepancy must be brought immediately to the notice of Ho Tin & Associates Consulting Engineers Limited.

All prints and copies of this drawing are the properties of Ho Tin & Associates Consulting Engineers Limited and shall be returned on completion of works.

Copyright of this drawing is reserved by Ho Tin & Associates Consulting Engineers Limited.

Note: This plan has been processed on a curtailed check basis under the centralized processing system as promulgated in PNAP APP-19. The date of the authorized person, registered structural engineer and/or registered geotechnical engineer concerned as specified under section 4(3)(b) and the provision of section 14(2)(c) of the Buildings Ordinance are of particular relevance in this regard.

Plan Approved

CHENG Han-on, Colin
Senior Building Surveyor
for BUILDING AUTHORITY
- 3 NOV 2022

REVISIONS

PROJECT

PROPOSED RESIDENTIAL CARE HOME FOR THE ELDERLY AT LOT NO. 2188 (FORMERLY LOTS 398 RP AND 404) IN D.D.121, TAI TAO TSUEN, HUNG SHUI KIU, YUEN LONG, N.T.

何田顧問工程師有限公司
HO TIN & ASSOCIATES
CONSULTING ENGINEERS LIMITED

DATE PRINTED

JOB NO. HT 21016

SCALE: 1 : 500 OR AS SHOWN - A1

DRAWN: A. CHENG

CHECKED: W. SETO

APPROVED: K. C. LEE

TITLE

PROPOSED EXTERNAL STORMWATER DRAINAGE AND SEWERAGE LAYOUT

DRAWING NO. HT 21016 / DD / 001

UM Wan-ying, Bernard Vincent, JPH/04
Authorized Person (List of Architects)
Registration No. AP(A) 4984

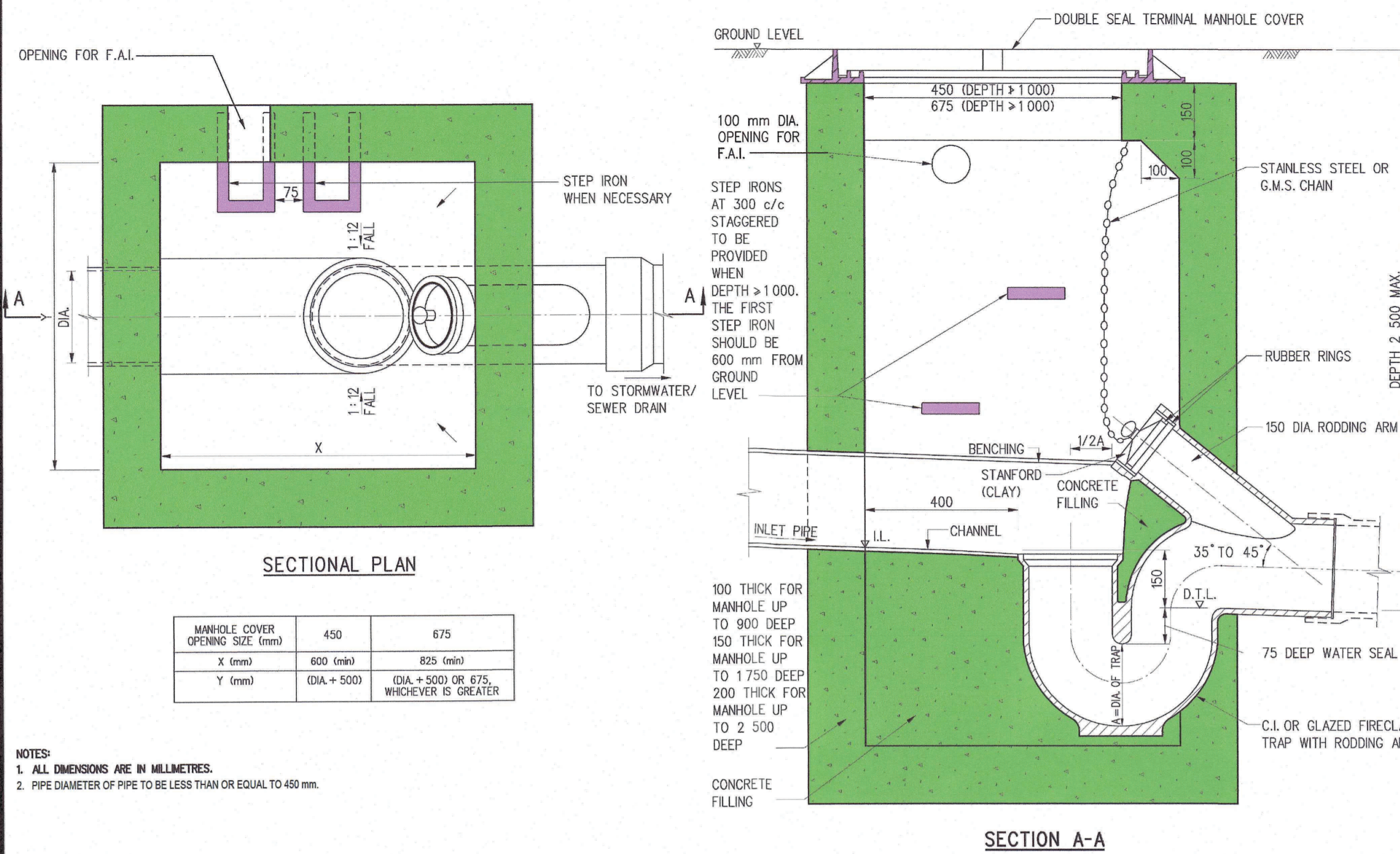

MANHOLE COVER OPENING SIZE (mm)	450	675
X (mm)	600 (min)	825 (min)
Y (mm)	(DIA + 500)	(DIA + 500) OR 675, WHICHEVER IS GREATER

- NOTES:
1. ALL DIMENSIONS ARE IN MILLIMETRES.
 2. PIPE DIAMETER OF PIPE TO BE LESS THAN OR EQUAL TO 450 mm.

TERMINAL MANHOLE TYPE T1_1

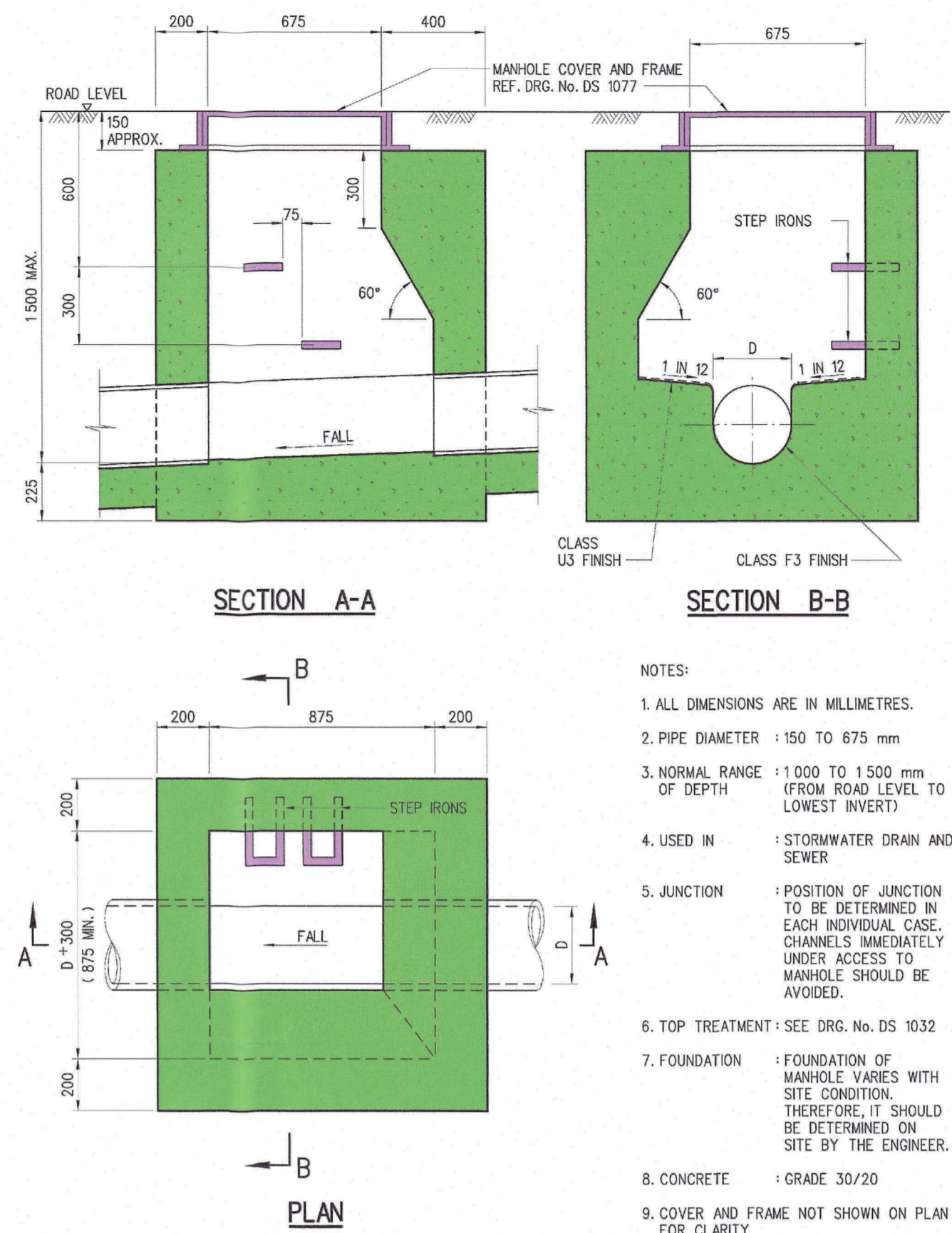

- NOTES:
1. ALL DIMENSIONS ARE IN MILLIMETRES.
 2. PIPE DIAMETER : 150 TO 675 mm
 3. NORMAL RANGE : 1 000 TO 1 500 mm OF DEPTH (FROM ROAD LEVEL TO LOWEST INVERT)
 4. USED IN : STORMWATER DRAIN AND SEWER
 5. JUNCTION : POSITION OF JUNCTION TO BE DETERMINED IN EACH INDIVIDUAL CASE. CHANNELS IMMEDIATELY UNDER ACCESS TO MANHOLE SHOULD BE AVOIDED.
 6. TOP TREATMENT : SEE DRG. No. DS 1032
 7. FOUNDATION : FOUNDATION OF MANHOLE VARIES WITH SITE CONDITION. THEREFORE, IT SHOULD BE DETERMINED ON SITE BY THE ENGINEER.
 8. CONCRETE : GRADE 30/20
 9. COVER AND FRAME NOT SHOWN ON PLAN FOR CLARITY

STANDARD MANHOLE TYPE D1
(FOR DSD & HYD REFERENCE, AND NOT FOR BD APPROVAL)

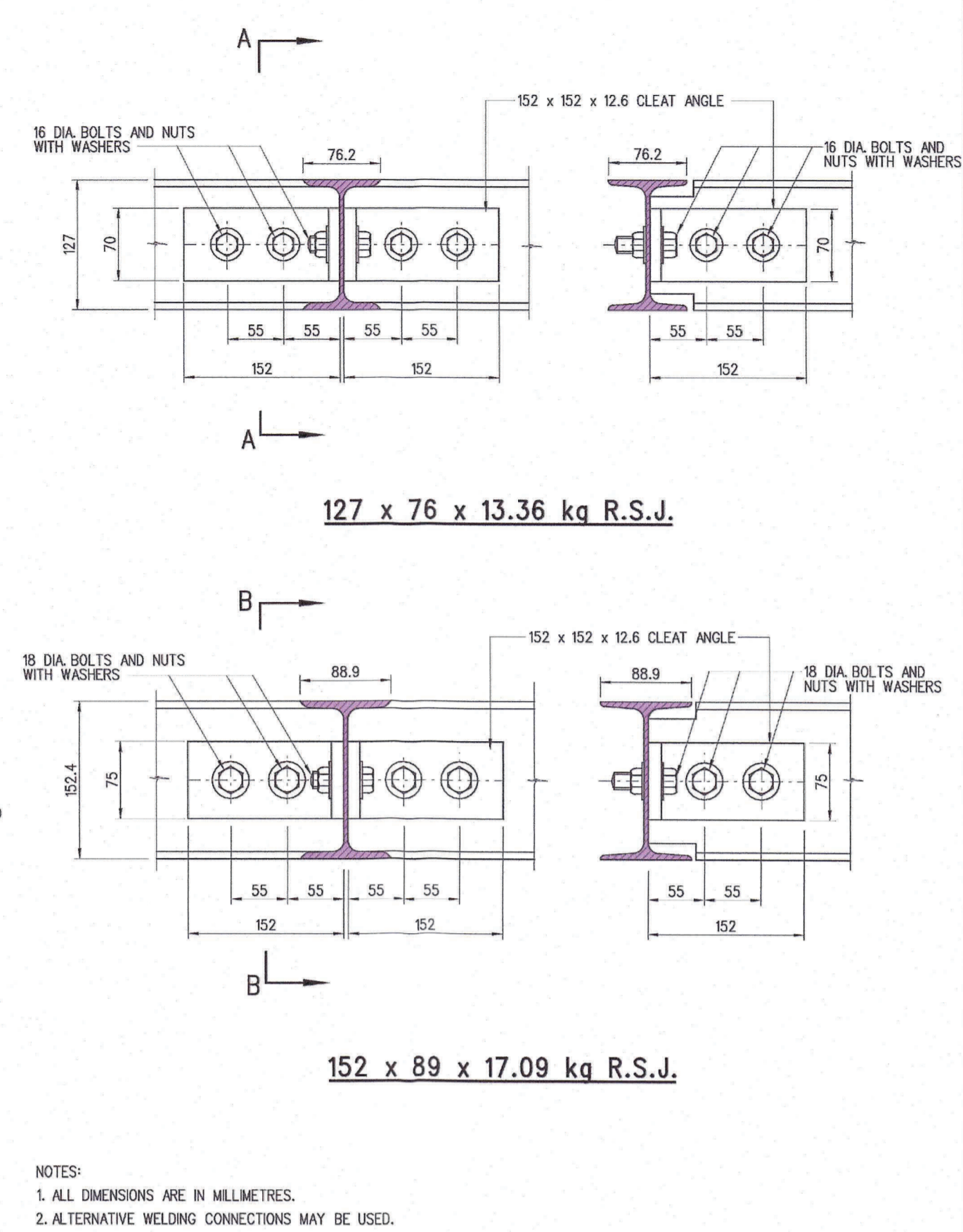

- NOTES:
1. ALL DIMENSIONS ARE IN MILLIMETRES.
 2. ALTERNATIVE WELDING CONNECTIONS MAY BE USED.

R. S. J. CONNECTIONS (IN MANHOLES)
(FOR DSD & HYD REFERENCE, AND NOT FOR BD APPROVAL)

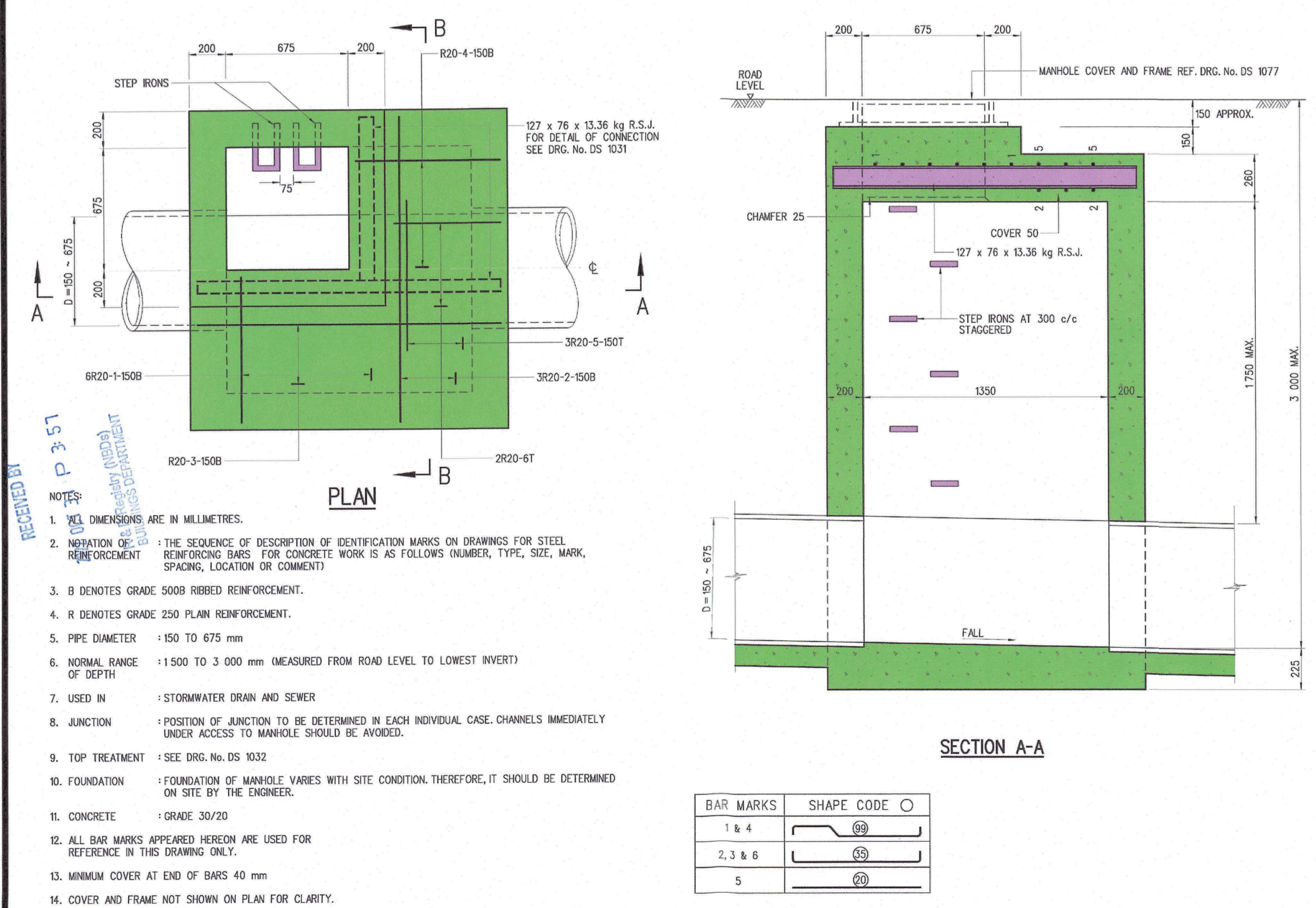

BAR MARKS	SHAPE CODE
1 & 4	⊖
2, 3 & 6	⊖
5	⊖

- NOTES:
1. ALL DIMENSIONS ARE IN MILLIMETRES.
 2. THE SEQUENCE OF DESCRIPTION OF IDENTIFICATION MARKS ON DRAWINGS FOR STEEL REINFORCING BARS FOR CONCRETE WORK IS AS FOLLOWS (NUMBER, TYPE, SIZE, MARK, SPACING, LOCATION OR COMMENT)
 3. B DENOTES GRADE 500B RIBBED REINFORCEMENT.
 4. R DENOTES GRADE 250 PLAIN REINFORCEMENT.
 5. PIPE DIAMETER : 150 TO 675 mm
 6. NORMAL RANGE OF DEPTH : 1 500 TO 3 000 mm (MEASURED FROM ROAD LEVEL TO LOWEST INVERT)
 7. USED IN : STORMWATER DRAIN AND SEWER
 8. JUNCTION : POSITION OF JUNCTION TO BE DETERMINED IN EACH INDIVIDUAL CASE. CHANNELS IMMEDIATELY UNDER ACCESS TO MANHOLE SHOULD BE AVOIDED.
 9. TOP TREATMENT : SEE DRG. No. DS 1032
 10. FOUNDATION : FOUNDATION OF MANHOLE VARIES WITH SITE CONDITION. THEREFORE, IT SHOULD BE DETERMINED ON SITE BY THE ENGINEER.
 11. CONCRETE : GRADE 30/20
 12. ALL BAR MARKS APPEARED HEREON ARE USED FOR REFERENCE IN THIS DRAWING ONLY.
 13. MINIMUM COVER AT END OF BARS 40 mm
 14. COVER AND FRAME NOT SHOWN ON PLAN FOR CLARITY.

STANDARD MANHOLE TYPE E1
(FOR DSD & HYD REFERENCE, AND NOT FOR BD APPROVAL)

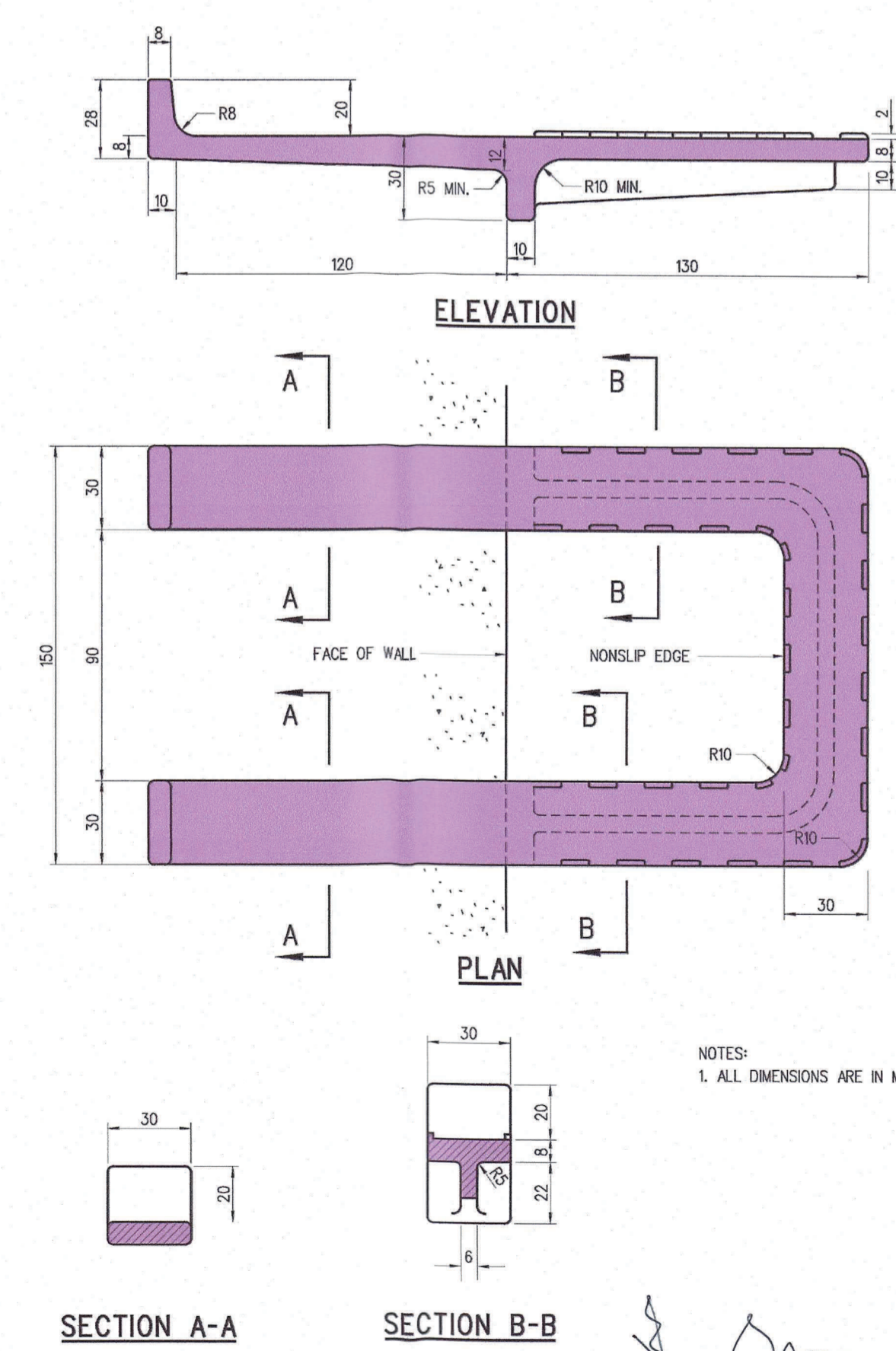
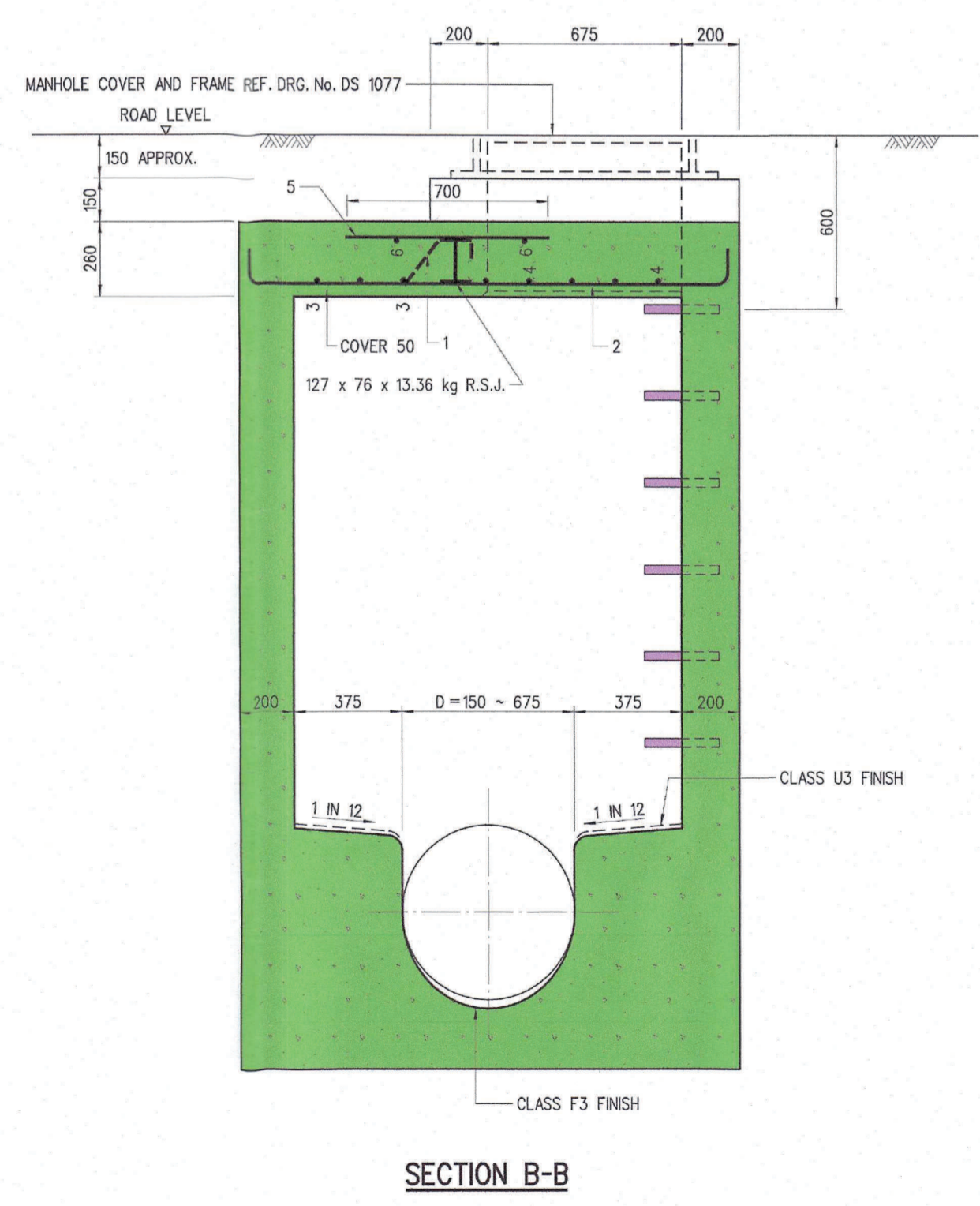

- NOTES:
1. ALL DIMENSIONS ARE IN MILLIMETRES.

MANHOLE STEP
Bernard Vincent, PPA/CA
Authorized Person (List of Architects)
Registration No. AP(A) 4884

B.D. REF.

F.S.D. REF.

Do not scale drawing

Figured dimensions are to be taken in preference to scaled dimensions in all cases.

Read this drawing in conjunction with general architectural plans, structural plans and other related drawings. Before commencing work, the full extent and exact nature of the works shown on this drawing shall be ascertained and all dimensions verified with site measurements. Any discrepancy must be brought immediately to the notice of Ho Tin & Associates Consulting Engineers Limited.

All prints and copies of this drawing are the properties of Ho Tin & Associates Consulting Engineers Limited and shall be returned on completion of works.

Copyright of this drawing is reserved by Ho Tin & Associates Consulting Engineers Limited.

Note: This plan has been processed on a controlled check basis under the e-control processing system as promulgated in PPA/CA ADM-18. The duties of the authorized person, registered structural engineer and/or registered geotechnical engineer concerned as specified under section 4(3)(b) and the provision of section 14(2)(c) of the Building Ordinance are of particular relevance in this regard.

Plan Approved

CHENG Hing-on, Colin
Senior Building Surveyor
for BUILDING AUTHORITY
- 3 NOV 2022

REVISIONS

PROJECT

PROPOSED RESIDENTIAL CARE HOME FOR THE ELDERLY AT LOT NO. 2188 (FORMERLY LOTS 398 RP AND 404) IN D.D.121, TAI TAO TSUEN, HUNG SHUI KIU, YUEN LONG, N.T.

何田顧問工程師有限公司
HO TIN & ASSOCIATES
CONSULTING ENGINEERS LIMITED

DATE PRINTED

JOB NO. HT 21016

SCALE: N. T. S.

DRAWN: A. CHENG

CHECKED: W. SETO

APPROVED: K. C. LEE

TITLE

PROPOSED MANHOLE DETAILS

DRAWING NO.

HT 21016 / DD / 003

**Appendix 2 - Copies of the relevant document submitted in associated with
the Drainage Plan to BD**

Drainage Proposal

in support of

**Proposed Social Welfare Facility (Residential Care Home for the Elderly (RCHE)) at Lot No. 2188
(former Lot Nos. 398 RP (Part) and 404) in D.D. 121,
Tai Tao Tsuen, Hung Shui Kiu, Yuen Long, New Territories**

(HT 21016)

August 2022

Drainage Consultant:

何田顧問工程師有限公司
HO TIN & ASSOCIATES
CONSULTING ENGINEERS LIMITED

Prepared and approved by:	K. C. LEE <i>RPE(Civil, Geo., Env.)</i> Telephone: [REDACTED] Email: [REDACTED]
---------------------------	---

CONTENT

1. Background
2. Objectives and Scope of this Report
3. The Subject Site and Proposed Development
4. Existing Drainage Conditions of the Subject Site
5. Approach and Methodology of Drainage Assessment
6. Proposed Drainage Works
7. Proposed Sewage Disposal Arrangement
8. Conclusion and Recommendations

FIGURES

Figure D1 - Drainage Path and Catchment Areas

Figure D2 - Extract of the Relevant Recorded Existing Drainage Information of the Area retrieved from the GEOINFO Map

Figure D3 - Existing Public Stormwater Drainage Layout in the Immediate Vicinity

Figure D4 - Proposed Stormwater Drainage Layout

DSD Standard Drawing No. DS 1090 (2 sheets)

Figure S1 - Proposed Connecting Sewerage in the Original Final SIA Report

Figure S2 - Amended Alignment of the Proposed Connecting Sewerage

Plan No. 3761/01 (3 sheets) - Topographic and Boundary Survey

APPENDIX

Appendix 1 - Hydraulic Calculations

Appendix 2 - Copy of the Final Sewerage Impact Assessment (SIA) Report submitted in support of the planning application in March 2018

1. Background

1.1 Ho Tin & Associates Consulting Engineers Limited was appointed by the Client to prepare this drainage proposal to satisfy the planning approval condition (f) of the Section 16 Planning Application No. A/YL-TYST/870.

1.2 A Drainage Proposal was submitted to PlanD in February 2022 and PlanD transmitted the following DSD's comments via a letter to the Applicant on 8 March 2022:

'In the submitted drainage proposal, only the proposed stormwater drainage arrangement was provided while the proposed sewage disposal arrangement was not mentioned. Please clarify your finalized sewage disposal proposal of either connection to the public sewer according to the SIA submitted via the subject planning application in 2018 or adoption of private sewage disposal facilities such as private sewage treatment works. You are required to provide supplementary information regarding sewage disposal arrangement.'

1.3 This Drainage Proposal has incorporated the DSD's comments to include a section of proposed sewage disposal arrangement, and is resubmitted for satisfying the relevant planning approval condition.

1.4 Further DSD's comments were received via PlanD's letters dated 29 April 2022 and 25 May 2022, and they have been responded in this resubmission. A summary of responses to the DSD's comments is enclosed in this report.

2. Objectives and Scope of this Report

2.1 The objective of this report is to propose drainage works in support of the proposed development (the 'subject development') in ensuring no unacceptable adverse drainage impact to be caused on the subject site and the surrounding areas, and seeking approvals of the PlanD and DSD in accordance with the planning approval condition. Besides, this report also reconfirms the proposed sewage disposal arrangement submitted during the planning application.

2.2 The scope of this report includes:

- (i) identifying existing drainage conditions of the subject area;
- (ii) evaluating flooding susceptibility and potential drainage impacts on the subject area;

- (iii) proposing drainage improvement works; and
- (iv) reconfirming the proposed sewage disposal arrangement.

3. The Subject Site and Proposed Development

3.1 The subject site comprises of Lot No. 2188 (former Lots 398 RP (Part) and 404) in D.D.121, Tai Tao Tsuen, Hung Shui Kiu, Yuen Long, New Territories. It has an area of about 1,798m² and is located on the southeastern side of the ‘Uptown’ residential development and is bounded by Fui Sha Wai South Road on the northeastern side. The site location is shown on **Figure D1**.

3.2 It is proposed to develop a Residential Care Home for the Elderly (RCHE) with the following parameters:







Parameter	Remark
Site area	About 1,798m ²
Plot ratio (PR)	Not more than 2.96
Gross floor area (GFA)	Not more than 5,313m ²
Height of building	Not exceeding 24m (in 7-storeys)
No. of beds	284



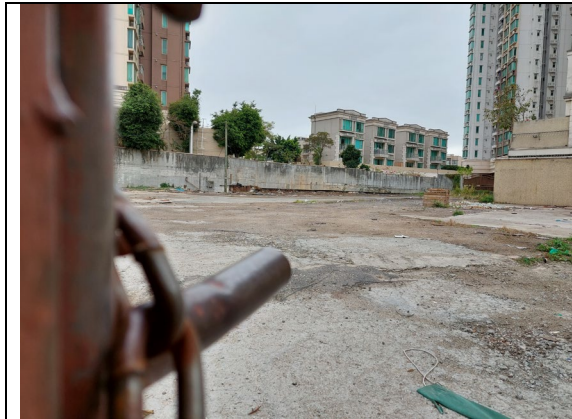

4. Existing Drainage Conditions of the Subject Site

4.1 The subject site is located on a generally flat area bounded by the ‘Uptown’ residential development and Fui Sha Wai South Road/Hung Tin Road which are now served by own stormwater drainage systems and would not discharge onto the subject site.

4.2 The subject site was previously used as open storage and is vacant at present. With respect to the drainage information retrieved recently from the GEOINFO Map, there should have an existing 450U channel running to the southeast in front of the northeastern boundary of the subject site. The 450U channel would discharge into a 525mm diameter drain and then into an existing 2000mm x 2000mm box culvert to the east of the subject site. An extract of the relevant recorded existing drainage information of the area retrieved from the GEOINFO Map is shown on **Figure D2**.

4.3 Site inspections were conducted recently. Colour photos (locations of the photo taken shown in **Figure D3**) showing the existing drainage conditions of the subject area are shown in the following:

	
<p>Plate No. 1 – Existing conditions of the subject site</p>	<p>Plate No. 2 – General view of Fui Sha Wai South Road in front of the subject site entrance (a refuse collection point is located on the opposite side of the subject site)</p>
	
<p>Plate No. 3 – Existing conditions of the subject site entrance (Existing Catchpit 1 is located on the right hand side of the entrance but no existing 450U channel is found)</p>	<p>Plate No. 4 – Existing Catchpit 1 and the adjacent existing U channel which is separated from the Existing Catchpit 1 and conveys flow toward Castle Peak Road</p>
	

<p>Plate No. 5 – Far view toward the existing 2000mm x 2000mm channel showing existing Catchpit 2 located beside Fui Sha Wai South Road</p>	<p>Plate No. 6 – Existing Catchpit 2 which should receive flow from an existing 450U channel and discharge into an existing 525mm diameter drain with respect to the GEOINFO Map</p>
	
<p>Plate No. 7 – View back toward the subject site entrance from the existing 2000mm x 2000mm channel/box culvert</p>	<p>Plate No. 8 – Existing 2000mm x 2000mm channel to the east of the subject site</p>
	
<p>Plate No. 9 – Existing outlet of the 525mm diameter drain at the existing 2000mm x 2000mm box culvert (under the road)</p>	<p>Plate No. 10 – Existing 2000mm x 2000mm channel to the east of the subject site (showing an existing outlet of the drain of the adjacent lot of the subject site)</p>

4.4 With respect to the recent site inspections, it is considered that the existing 450U channel in front of the subject site shown in the GEOINFO Map has been damaged and the existing 525mm diameter drain between the existing Catchpit 2 and its Outlet at the existing 2000mm x 2000mm box culvert still exists.

5. Approach and Methodology of Drainage Assessment

- 5.1 Capability of the existing drainage is assessed and new drainage is proposed in this report. Assessment criteria is based on the recommendation set out in the Stormwater Drainage Manual (Fifth edition, Jan 2018) (SDM) issued by DSD. The corresponding runoffs under rainfall intensity for various return period are worked out with reference to Rational Method with incorporation of effects due to climate change. The projection of rainfall increase percentage given in Table 28 in SDM, i.e. 13.8%, is added to the respective design rainfall intensities in the assessment.
- 5.2 Flow directions of the surface runoff and catchment boundaries of the subject area is shown in **Figure D1**, and assessment of the major drainage is illustrated in the **Appendix 1** of this report.
- 5.3 The subject proposed development would not alter the existing drainage patterns of the area and the surface runoff of the subject proposed development would be properly collected and conveyed to an appropriate discharge point. No blockage of any existing flow paths would be incurred.

6. Proposed Drainage Works

- 6.1 Peripheral channels with catchpits will be constructed to intercept all surface runoff running across the subject site boundary. Stormwater falling onto the roofs of the proposed building(s) of the subject development will be collected and conveyed to proposed channels on ground level by building drains. The flows inside the surface channels and peripheral channels will be eventually discharged into a terminal manhole with desilting trap (details refer to DSD Standard Drawing No. DS 1090) from which the flows will be further discharged into the existing Catchpit 1 outside the subject site entrance. A new 450mm diameter drain will be constructed to connect between the existing Catchpit 1 and Catchpit 2.
- 6.2 With respect to the hydraulic assessment enclosed in the **Appendix 1** of this report, the existing 525mm diameter drain at the downstream of the Catchpit 2 is still adequate to properly convey the estimated peak flow, i.e. the flow in 1 in 200 year return period rainfalls, into the existing 2000mm x 2000mm box culvert to the east of the subject site without causing any flooding.

- 6.3 Capacity of the existing 2000mm x 2000mm channel/box culvert has also been assessed and is confirmed to be adequate to convey the estimated peak flow without flooding.
- 6.4 A proposed stormwater drainage layout is shown on **Figure D4**. Detailed designs of the drainage system (including building drains) will be submitted to relevant government departments via Buildings Department's central processing mechanism for approval at the later stage. No insurmountable technical problems is envisaged.
- 6.5 The applicant is committed to obtain all necessary consents from the relevant government departments and lot owners, where necessary, in constructing the proposed drainage provisions outside the subject site boundary before construction.

7. Proposed Sewage Disposal Arrangement

- 7.1 During processing of the Planning Application No. A/YL-TYST/870, a Final Sewerage Impact Assessment (SIA) Report was submitted in support of the planning application in March 2018. It was proposed to connect the sewerage of the subject development via a proposed sewerage running underneath Fui Sha Wai South Road and the emergency vehicular access to the nearest public sewerage manhole at the westbound of Castle Peak Road in front of the Uptown Tower 1. A copy of the Final SIA Report is enclosed in **Appendix 2** in this report. The Existing and Proposed Sewerage Layout Plan enclosed in the Final SIA Report is reproduced as **Figure S1** in this report for easy reference.
- 7.2 Development parameters of the subject development would remain unchanged, otherwise application to the Government shall be made, in the planning application and in the detailed design for implementation. Therefore the assessment and conclusion in the original Final SIA Report (i.e. in the **Appendix 2** of this report) are still valid.
- 7.3 However, in order to enhance the alignment of the proposed connecting sewerage between the subject development and the nearest public sewerage manhole, it is proposed to realign the proposed connecting sewerage as shown in **Figure S2**. Since the proposed amendments would mainly only shorten the total length of the proposed sewerage alignment, there is no change in the total design sewage flows. Hence, it would not incur any adverse effects upon the existing sewerage system. Detailed

design of the proposed sewerage connecting works will be submitted to the Building Authority who will circulate the submission to all relevant departments by means of central processing mechanism for comment, for approval prior to commencement of the construction works.

- 7.4 With respect to the original submission enclosed in the **Appendix 2** of this report with modification to reflect the proposed shorter alignment, cover of the proposed sewer at carriageway is shown below for information:

Manhole ID	Ground Level* (mPD) (1)	Invert Level (mPD) (2)	Crown Level (mPD) (for DN225 SDR 7.4 sewer, wall thickness = 30.8mm, mean I.D. = 161mm) (3) = (2) + 0.161 + 0.0308	Pipe Cover (m) (4) = (1) – (3)
HSK-01	10.83	10.18	10.37	0.46
HSK-02	10.59	9.51	9.70	0.89
HSK-03	10.20	9.09	9.28	0.92
HSK-04	10.30	8.60	8.79	1.51
FMH1036685	10.30	8.45	8.64	1.66

* referenced to the latest topographical survey results enclosed in this report

It is noticed from the above table that standard cover of 900mm at carriageway might not be achieved at the section of the proposed sewer near the subject site boundary. Invert levels of the proposed sewer will be fine-tuned during detailed design such that the standard cover of 900mm at carriageway will be achieved, or otherwise the applicant shall seek approval from the maintenance authority of the road, i.e. HyD, and concrete surround as recommended in DSD PN No. 1/2019 will be proposed for the proposed sewer with cover less than 900mm at carriageway.

8. Conclusion and Recommendations

- 8.1 The subject site area is now vacant. It is proposed to be developed into a RCHE.

- 8.2 All stormwater collected by the surface channels and building drains of the subject development will be conveyed into a terminal manhole with desilting trap from which the flows will be discharged to the existing Catchpit 1 outside the subject site entrance. The existing Catchpit 1 and Catchpit 2 outside the subject site boundary will be maintained and made good if necessary, and a new 450mm diameter drain will be laid between the two catchpits to convey flows to the further downstream. The existing 525mm diameter drain between the Catchpit 2 and the outlet at the existing 2000mm x 2000mm box culvert to the east of the subject site was checked to be adequate to convey the estimated peak flow. The flow incurred by the subject development would not overload the existing drainage of the subject area.
- 8.3 Sewerage connection between the subject development and the nearest public sewerage manhole will be implemented as proposed in the original Final SIA Report. Alignment of the proposed connecting sewerage will be amended to shorten the overall flow path as shown in **Figure S2**. Invert levels of the proposed sewer will be fine-tuned during detailed design to ensure that the standard cover of 900mm at carriageway will be achieved, or otherwise the applicant shall seek approval from the maintenance authority of the road, i.e. HyD, and concrete surround as recommended in DSD PN No. 1/2019 will be proposed for the proposed sewer with cover less than 900mm at carriageway.
- 8.4 Detailed drainage and sewerage connecting works designs will be submitted to the Building Authority for central processing for approval at the later stage. No insurmountable technical problems is envisaged.
- 8.5 The applicant will obtain all necessary consents from the relevant government departments and lot owners, where necessary, for constructing the proposed drainage and sewerage provisions outside the subject site boundary prior to construction.
- 8.6 The subject proposed development would not alter the existing drainage patterns and flow paths of the area. Besides, there is no change in the designed sewage flow between the proposal in the subject planning application and the development to be implemented. In conclusion, the subject development with implementation of the proposed drainage and sewerage connecting works will not cause any adverse drainage and sewerage impacts onto the area.

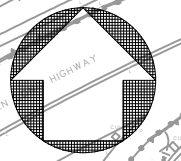
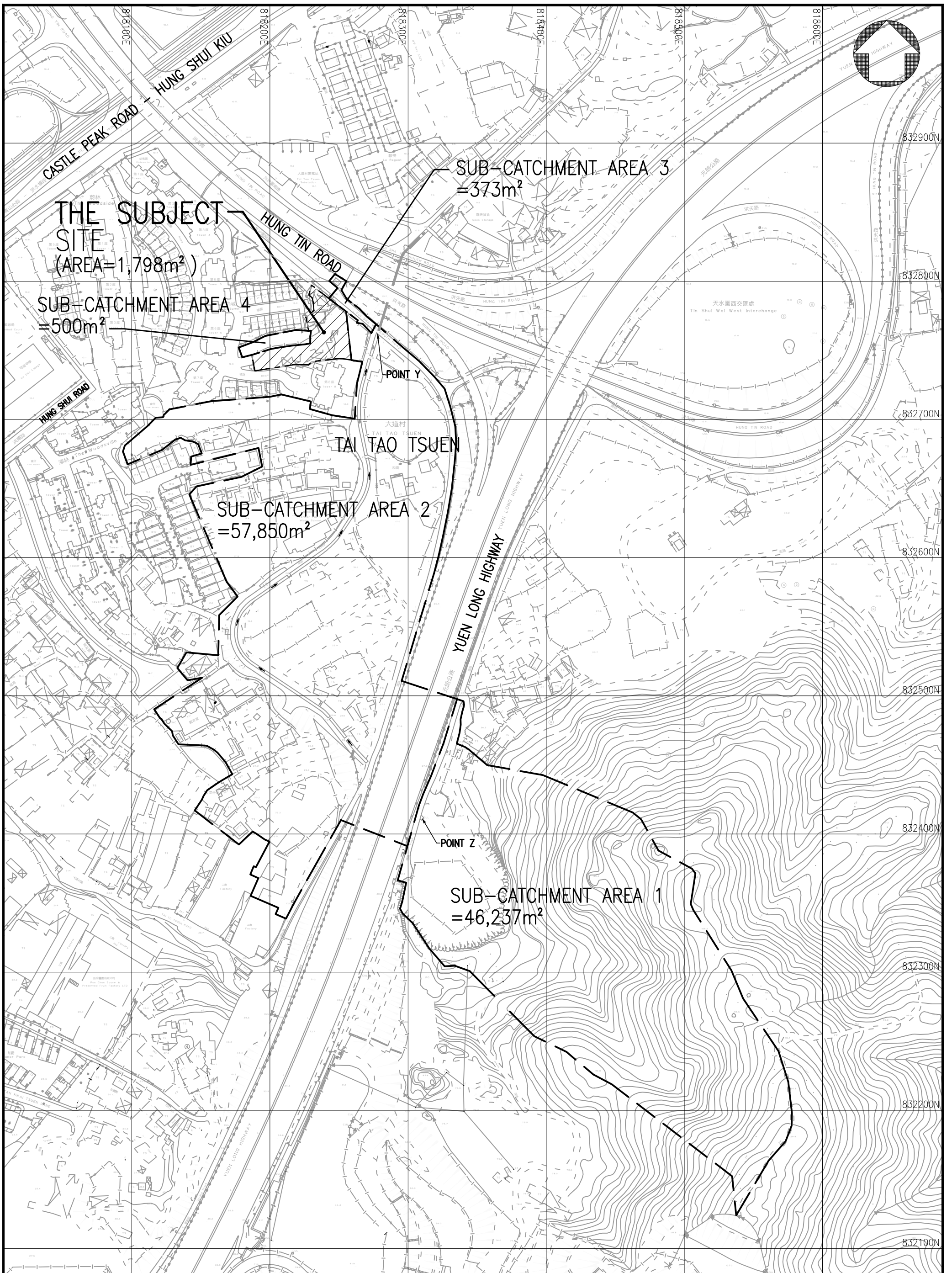

PROJECT
 PROPOSED SOCIAL WELFARE FACILITY (RESIDENTIAL CARE HOME FOR THE ELDERLY (RCHE)) AT LOT NO.2188
 (FORMER LOTS 398 RP (PART) AND 404) IN D.D.121, TAI TAO TSUEN, HUNG SHUI KIU, YUEN LONG, N.T.

何田顧問工程師有限公司
HO TIN & ASSOCIATES
 CONSULTING ENGINEERS LIMITED

TITLE
 DRAINAGE PATH AND CATCHMENT AREAS

SCALE
 1 : 2500

DRAWING No.
 FIGURE D1

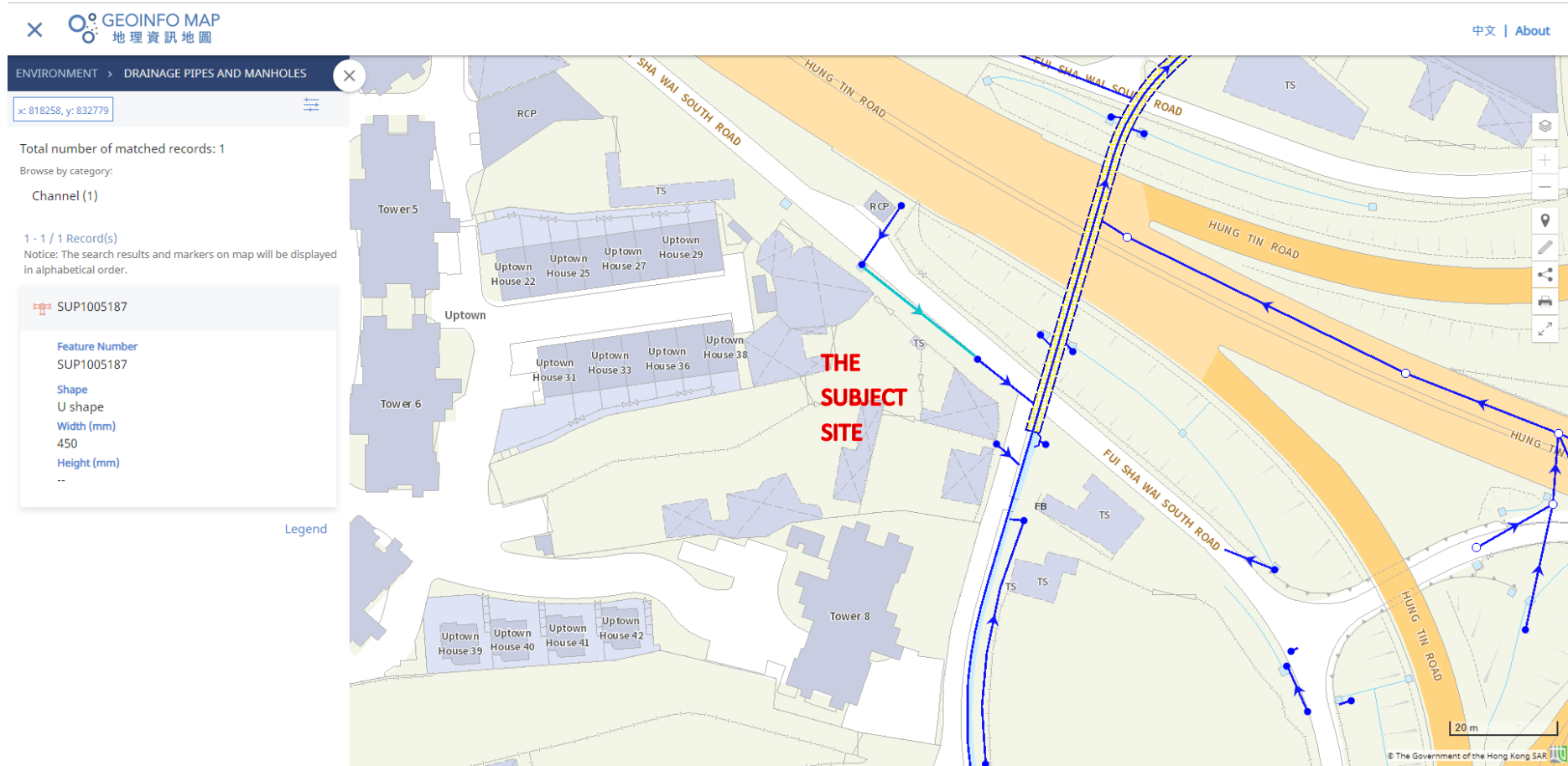
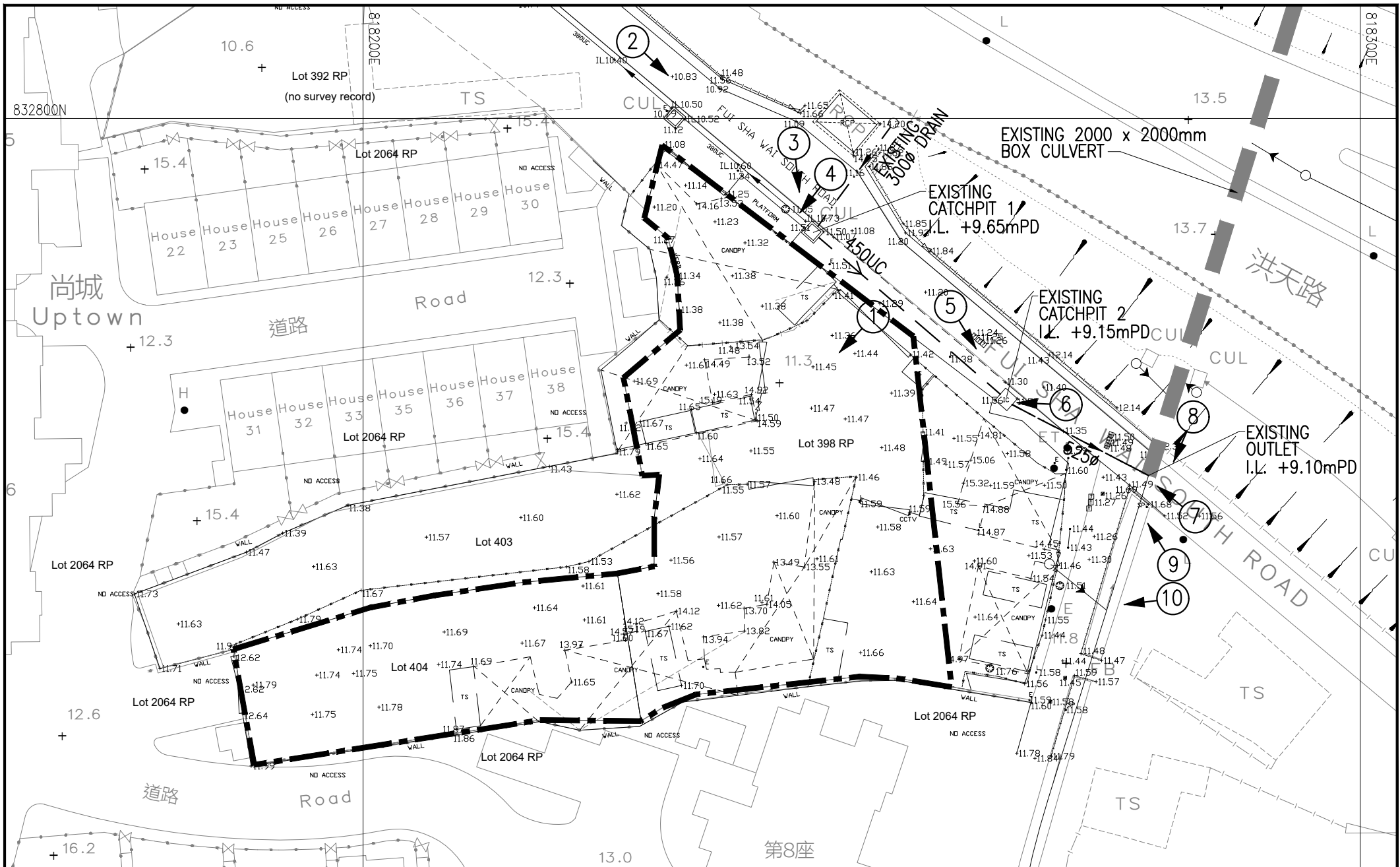

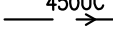
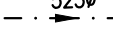



FIGURE D2 - Extract of the Relevant Recorded Existing Drainage Information of the Area retrieved from the GEOINFO Map



LEGEND:

-  THE SUBJECT SITE
-  EXISTING U-CHANNEL
-  EXISTING DRAIN
-  LOCATION OF PHOTO TAKEN (N-PLATE NO.)
-  EXISTING STORMWATER DRAINAGE

PROJECT
PROPOSED SOCIAL WELFARE FACILITY (RESIDENTIAL CARE HOME FOR THE ELDERLY (RCH)) AT LOT NO.2188 (FORMER LOTS 398 RP (PART) AND 404) IN D.D.121, TAI TAO TSUEN, HUNG SHUI KIU, YUEN LONG, N.T.

TITLE
EXISTING PUBLIC STORMWATER DRAINAGE LAYOUT IN THE IMMEDIATE VICINITY (REFERS TO GEOINFO MAP'S INFORMATION)

何田顧問工程師有限公司
HO TIN & ASSOCIATES
 CONSULTING ENGINEERS LIMITED

SCALE
 1 : 500

DRAWING No.
FIGURE D3

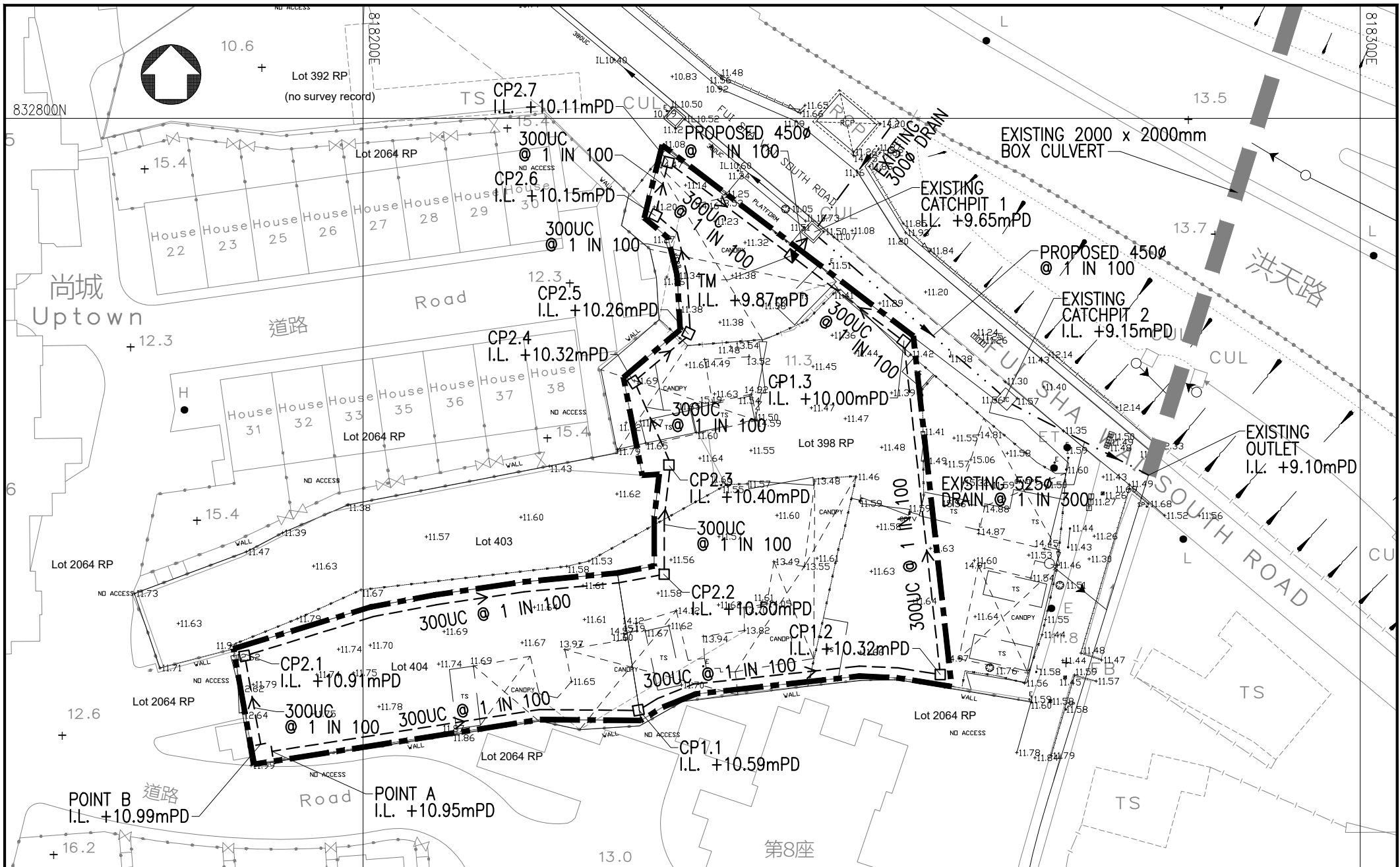

HA\21016-rche\DRAWING\21016DD01_for BD.dwg, 31/08/2022 10:33:30, DWG To PDF.pcf.3

LEGEND: THE SUBJECT SITE PROPOSED TERMINAL MANHOLE PROPOSED U-CHANNEL PROPOSED DRAIN PROPOSED CATCH PIT EXISTING DRAIN EXISTING STORMWATER DRAINAGE		PROJECT PROPOSED SOCIAL WELFARE FACILITY (RESIDENTIAL CARE HOME FOR THE ELDERLY (RCHC)) AT LOT NO.2188 (FORMER LOTS 398 RP (PART) AND 404) IN D.D.121, TAI TAO TSUEN, HUNG SHUI KIU, YUEN LONG, N.T.	何田顧問工程師有限公司 HO TIN & ASSOCIATES CONSULTING ENGINEERS LIMITED
TITLE PROPOSED STORMWATER DRAINAGE LAYOUT		SCALE 1 : 500 - A4	DRAWING No. FIGURE D4

OPENING FOR F.A.I.
(FOR SEWER MANHOLE ONLY)

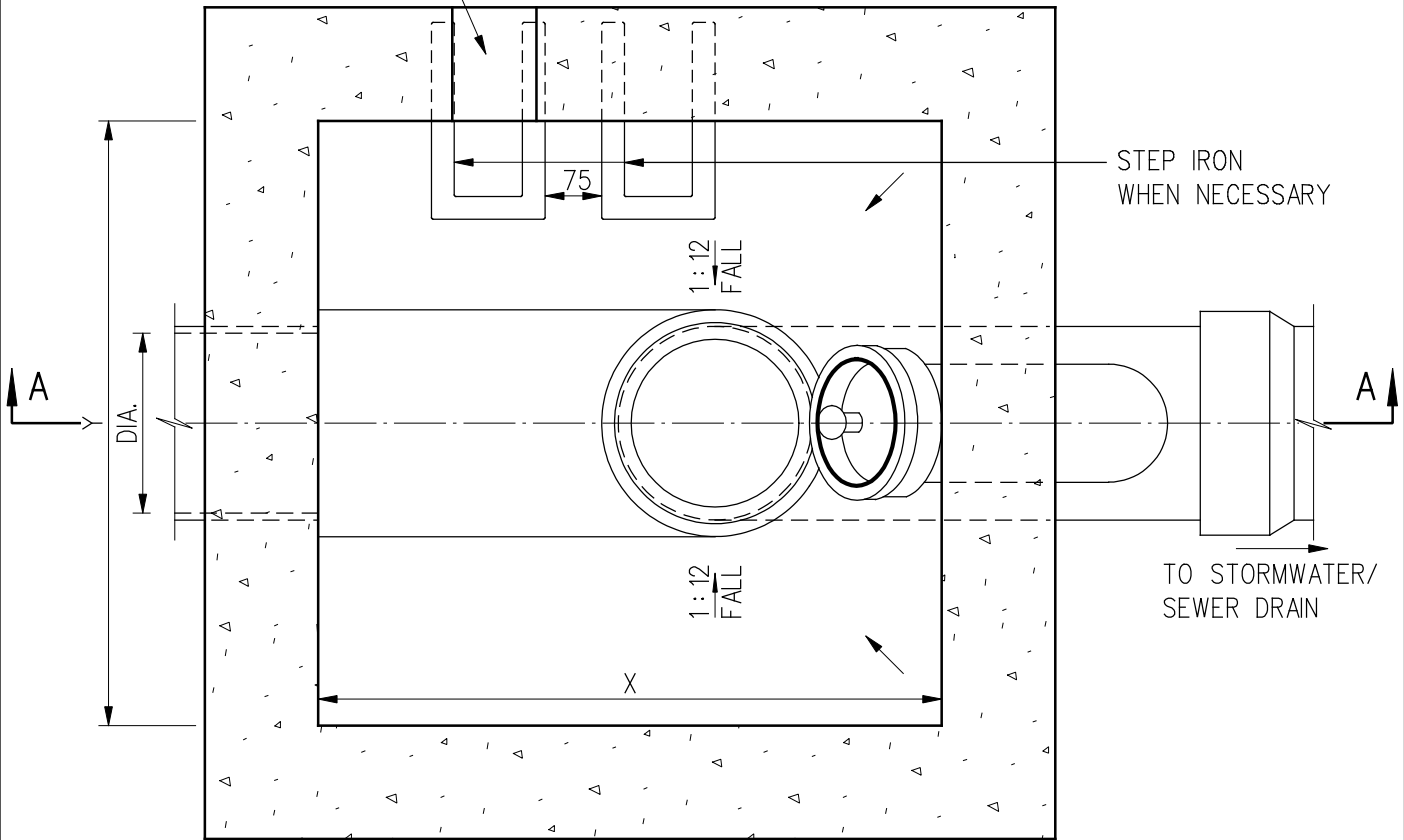

SECTIONAL PLAN

MANHOLE COVER OPENING SIZE (mm)	450	675
X (mm)	600 (min)	825 (min)
Y (mm)	(DIA. + 500)	(DIA. + 500) OR 675, WHICHEVER IS GREATER

NOTES:

1. ALL DIMENSIONS ARE IN MILLIMETRES.
2. CONCRETE IS TO BE GRADE 30/20.
3. PIPE DIAMETER OF PIPE TO BE LESS THAN OR EQUAL TO 450 mm.

REV.	NEW ISSUE	ORIGINAL SIGNED	13.1.2016
REV.	DESCRIPTION	SIGNATURE	DATE

**TERMINAL MANHOLE
TYPE T1_1**

DRAINAGE SERVICES DEPARTMENT

REFERENCE

DRAWING No.

SCALE

1 : 10

DS 1090
(SHEET 1 OF 2)

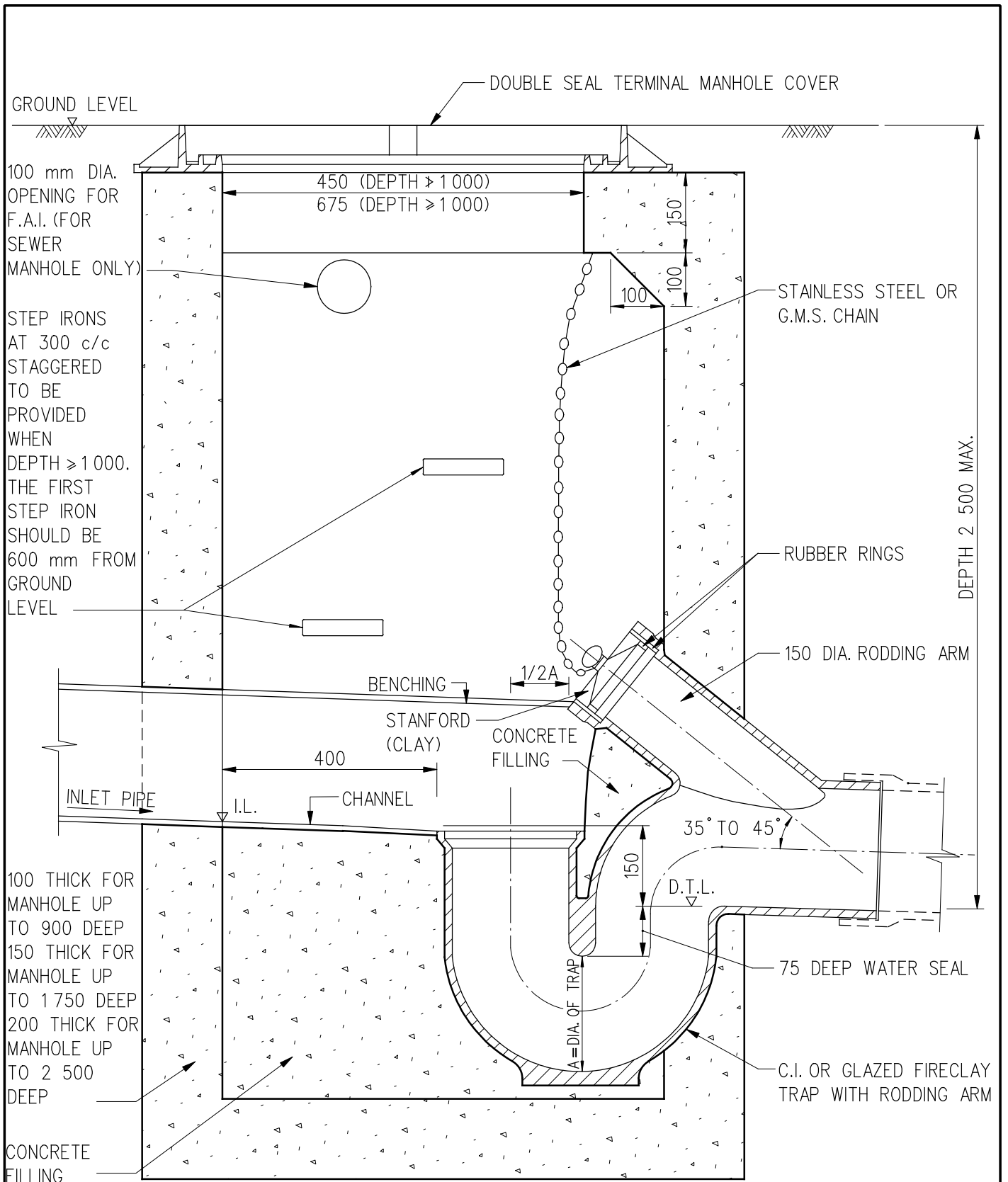

SECTION A-A

**TERMINAL MANHOLE
TYPE T1_1**

	NEW ISSUE	ORIGINAL SIGNED	13.1.2016
REV.	DESCRIPTION	SIGNATURE	DATE
DRAINAGE SERVICES DEPARTMENT			
REFERENCE	DRAWING No.		
SCALE	DS 1090		
	(SHEET 2 OF 2)		

1 : 10

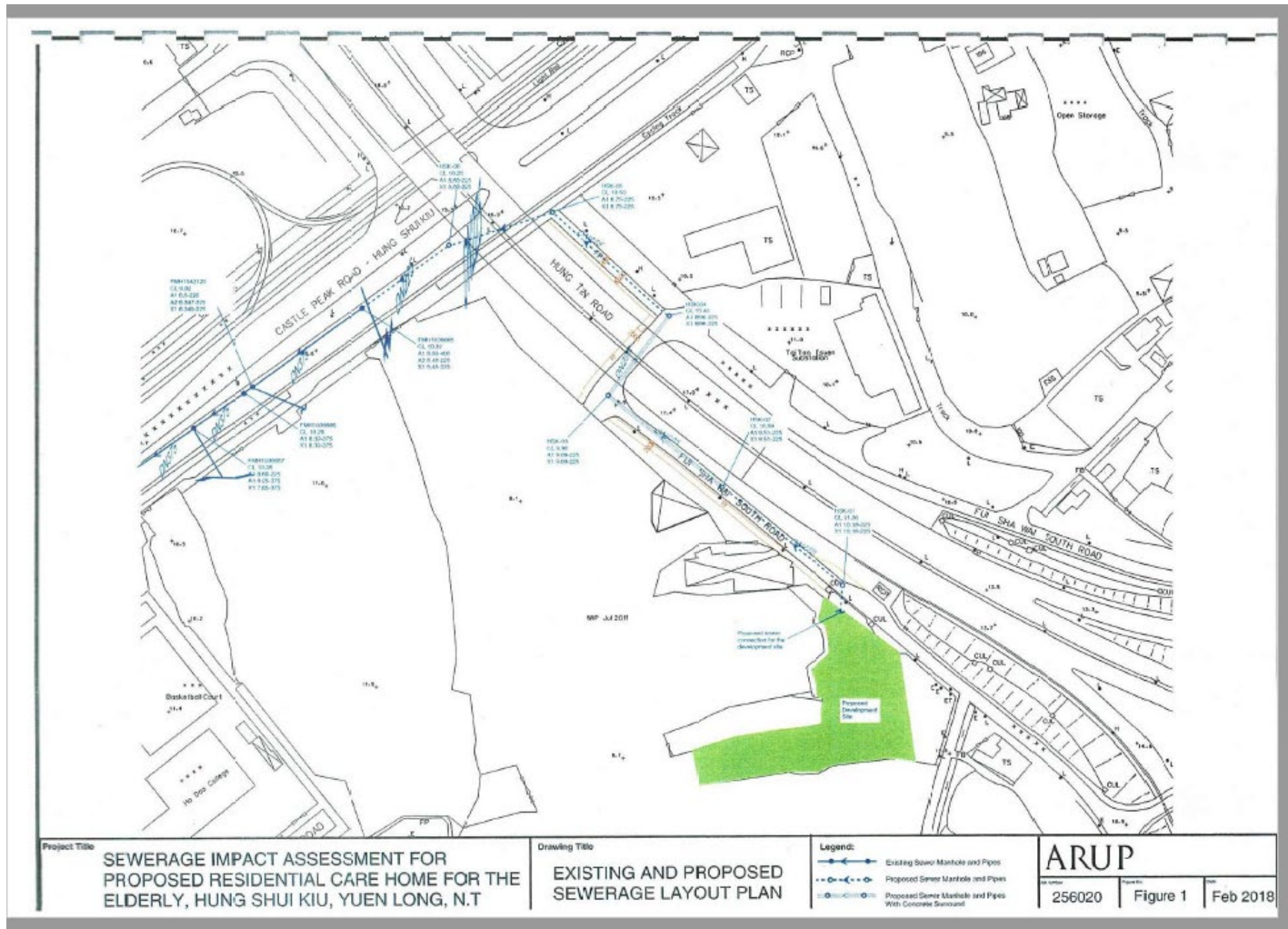

FIGURE S1 - Proposed Connecting Sewerage in the Original Final SIA Report

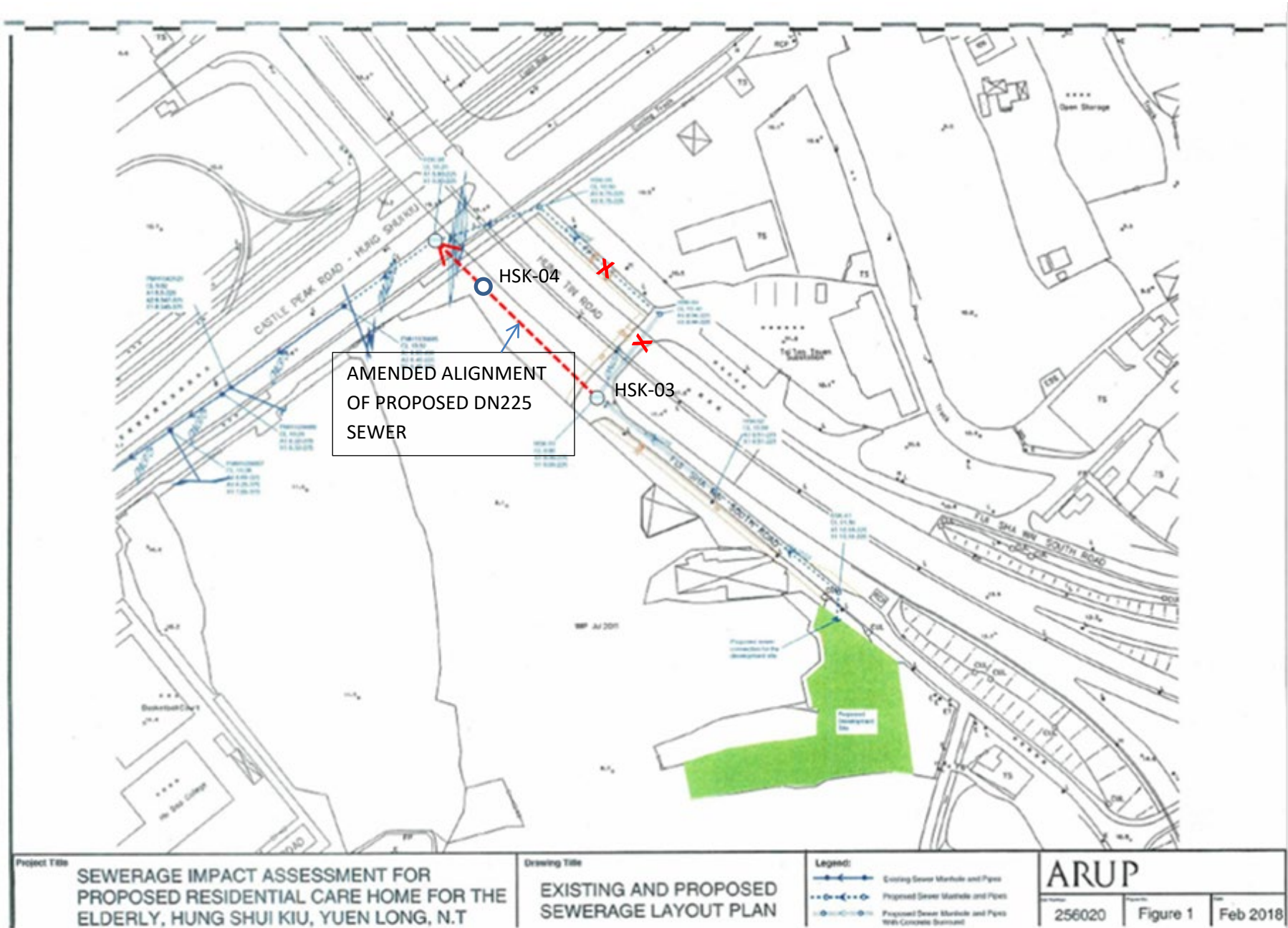
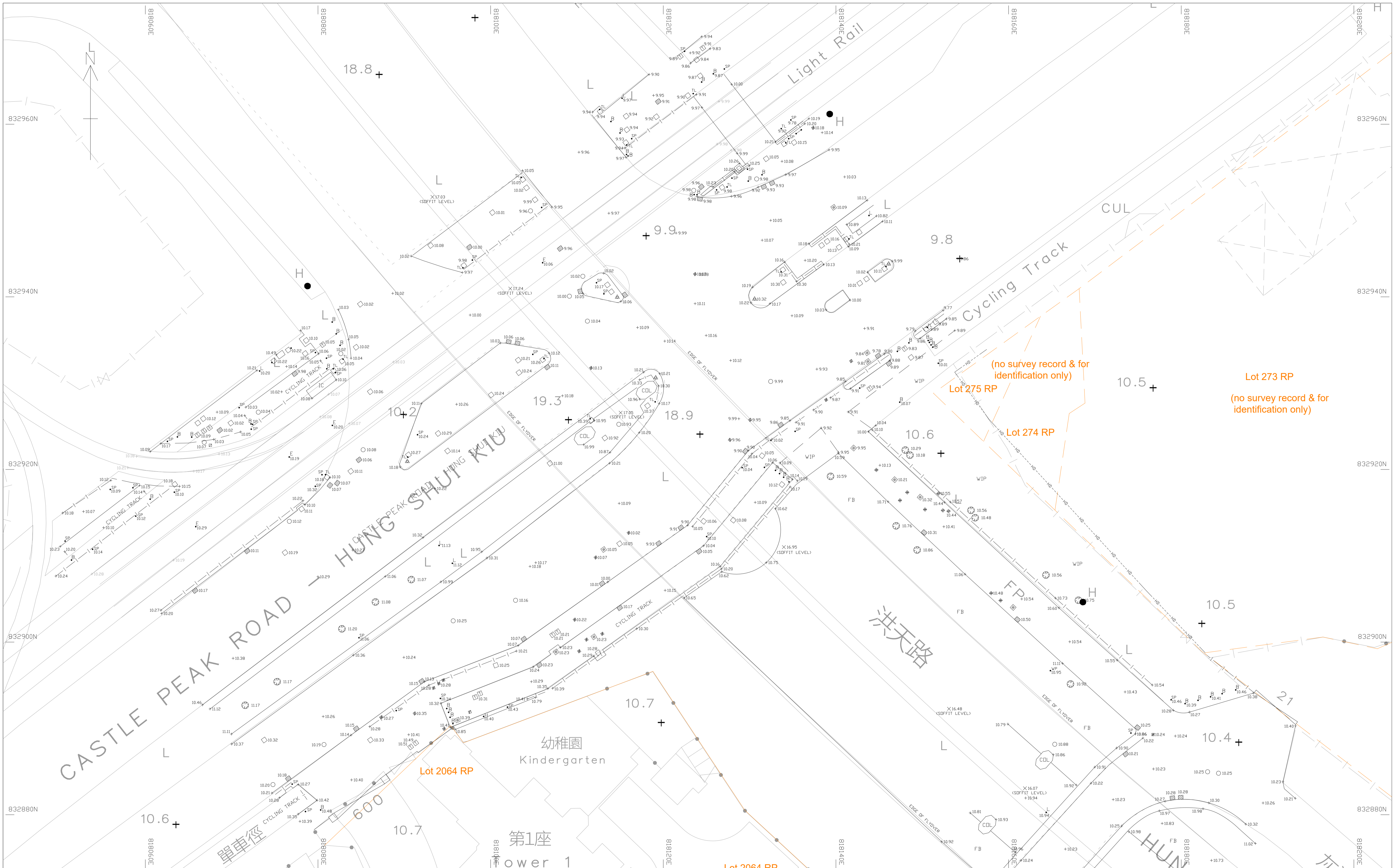

FIGURE S2 - AMENDED ALIGNMENT OF THE PROPOSED CONNECTING SEWERAGE



ABBREVIATIONS :-		SYMBOLS :-	
BH	BORE HOLE	---	BALCONY / CANOPY
CB	CONCRETE BLOCK	▭	BUILDING
CC	COVERED CHANNEL	- - -	FENCE/RAILING
CL	COVER LEVEL	▭	HOARDING
CP	CATCHPIT	—	SITE BOUNDARY
CO	COLUMN	↘	SLOPE
CV	CULVERT	○	BOLLARD
DR	DRAIN	□	BOUNDARY STONE
FB	FLOWER BED	●	ELECTRIC POLE
FBR	FOOTBRIDGE	⊕	FIRE HYDRANT
FP	FOOTPATH	⊕	GATE
PLF	PLATFORM	⊕	GRATING
PND	POND	⊕	LAMP POST
IC	INSPECTION COVER	⊕	MANHOLE/ MANHOLE FOUL
IL	INVERT LEVEL	○	MANHOLE STORM
RCP	REFUSE COLLECTION POINT	⊕	MANHOLE TELEPHONE
SHR	SHRINE	⊕	MANHOLE WATERWORKS
SO	SOFFIT LEVEL	⊕	PARKING METER POST
TS	TEMPORARY STRUCTURE	⊕	SIGN POLE
UC	U CHANNEL	⊕	SIGN BOARD
WIP	WORKS IN PROGRESS	⊕	SHRINE
		⊕	TELEPHONE POLE
		⊕	TELEPHONE KIOSK
		⊕	TRAFFIC LIGHT
		⊕	LIGHT BOX
		⊕	TRAFFIC LIGHT CONTROL BOX
		⊕	TREE
		⊕	UTILITY CONTROL BOX
		⊕	GULLY
		⊕	VALVE FIRE
		⊕	VALVE GAS
		⊕	VALVE WATERWORKS
		⊕	WATER TAP

SCALE 1 : 200 (Size A1)

DATE OF SURVEY : JUNE 2021

NOTE :-

- 1) ALL SPOT LEVEL POSITIONS ARE INDICATED BY A CROSS.
- 2) ALL GRID LINES ARE IN HONG KONG 1980 PRINCIPAL DATUM
- 3) ALL UNITS ARE IN METRES

Lots 389RP(part) and 404 in DD121
Tai Tao Tsuen, Hung Shui Kiu, Yuen Long

TOPOGRAPHIC AND BOUNDARY SURVEY

CHYNCHEN ASSOCIATES LIMITED
CHARTERED LAND SURVEYORS

PLAN NO.3761/01

REVISION NO.	DESCRIPTIONS	DATE

DRAWN BY: HENI
CHECKED BY: WING LAM
APPROVED BY:

1/2 DAT MENG HENRY 1/2021 WING WING WONG ASLS

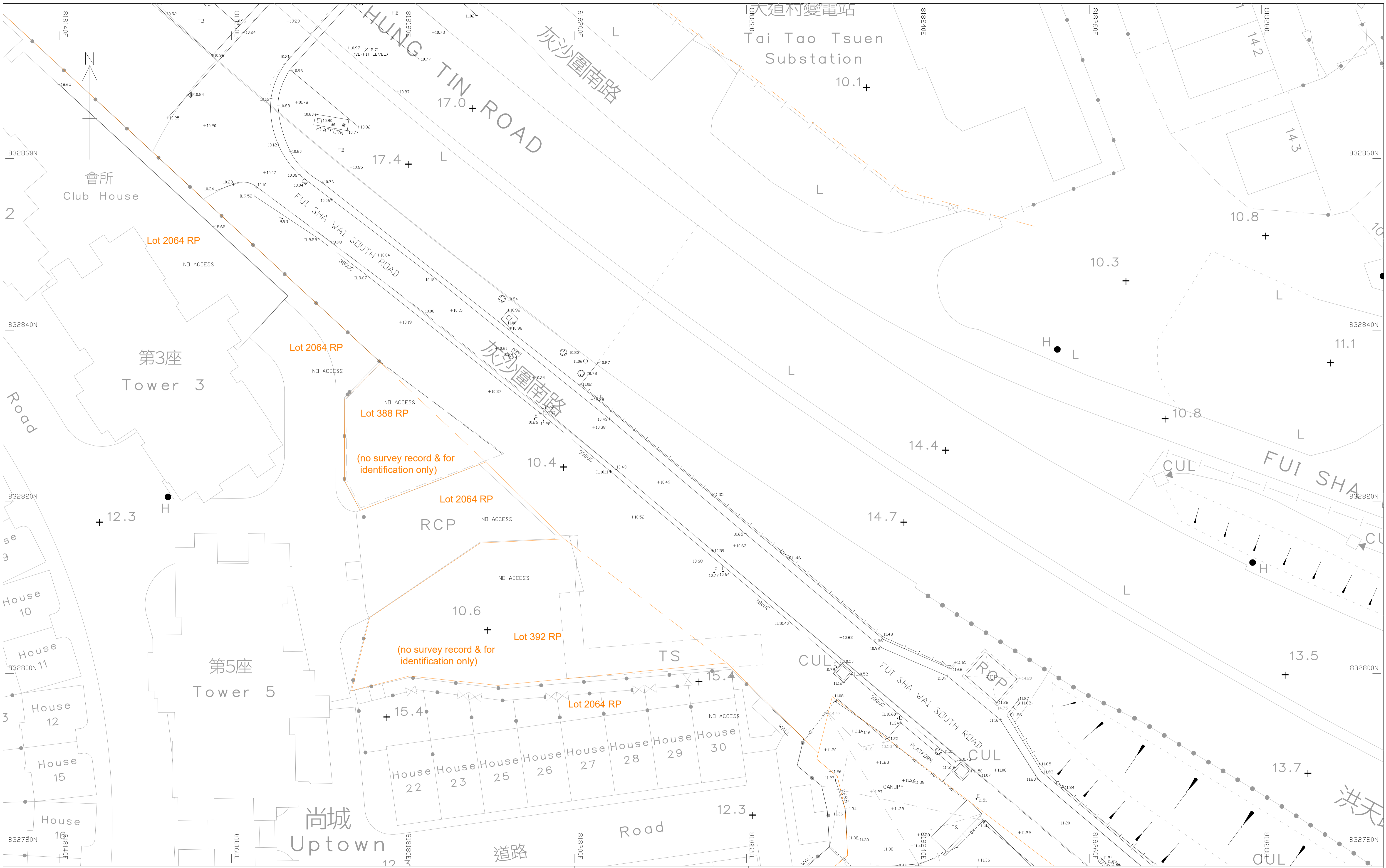

ABBREVIATIONS :-		SYMBOLS :-	
BH	BORE HOLE	---	BALCONY / CANOPY
CB	CONCRETE BLOCK	▬▬▬	BUILDING
CC	COVERED CHANNEL	- - - -	FENCE/RAILING
CL	COVER LEVEL	▬▬▬	HOARDING
CP	CATCHPIT	—	SITE BOUNDARY
CO	COLUMN	▬▬▬	SLOPE
CV	CULVERT		
DR	DRAIN		
FB	FLOWER BED		
FBR	FOOTBRIDGE		
FP	FOOTPATH		
PLF	PLATFORM		
PND	POND		
IC	INSPECTION COVER		
IL	INVERT LEVEL		
ICP	REFUSE COLLECTION POINT		
SHR	SHRINE		
SO	SOFFIT LEVEL		
TS	TEMPORARY STRUCTURE		
UC	U CHANNEL		
WIP	WORKS IN PROGRESS		
B	BOLLARD		
BS	BOUNDARY STONE		
E	ELECTRIC POLE		
H	FIRE HYDRANT		
G	GATE		
GR	GRATING		
L	LAMP POST		
M	MANHOLE / MANHOLE FOUL		
MS	MANHOLE STORM		
T	MANHOLE TELEPHONE		
W	MANHOLE WATERWORKS		
PZ	PIEZOMETER TUBE		
PM	PARKING METER POST		
SP	SIGN POLE		
SB	SIGN BOARD		
SH	SHRINE		
TP	TELEPHONE POLE		
TK	TELEPHONE KIOSK		
TL	TRAFFIC LIGHT		
L	LIGHT BOX		
TL	TRAFFIC LIGHT CONTROL BOX		
T	TREE		
UCB	UTILITY CONTROL BOX		
G	GULLY		
V	VALVE FIRE		
V	VALVE GAS		
V	VALVE WATERWORKS		
W	WATER TAP		

SCALE 1 : 200 (Size A1)

DATE OF SURVEY : JUNE 2021

NOTE :-

- 1) ALL SPOT LEVEL POSITIONS ARE INDICATED BY A CROSS.
- 2) ALL GRID LINES ARE IN HONG KONG 1980 PRINCIPAL DATUM
- 3) ALL UNITS ARE IN METRES

Lots 389RP(part) and 404 in DD121
Tai Tao Tsuen, Hung Shui Kiu, Yuen Long

TOPOGRAPHIC AND BOUNDARY SURVEY

CHYNCHEN ASSOCIATES LIMITED
CHARTERED LAND SURVEYORS

PLAN NO.3761/01

REVISION NO.	DESCRIPTIONS	DATE	APPROVED BY:

DRAWN BY: KENNETH
CHECKED BY: WINGO LAW
APPROVED BY:
NG TAT MING HENRY WONG WAI SANG A.S.



ABBREVIATIONS :-		SYMBOLS :-	
BH	BORE HOLE	---	BALCONY / CANOPY
CB	CONCRETE BLOCK	▬	BUILDING
CC	COVERED CHANNEL	- - -	FENCE/RAILING
CL	COVER LEVEL	---	HOARDING
CP	CATCHPIT	---	SITE BOUNDARY
CO	COLUMN	---	SLOPE
CV	CULVERT		
DR	DRAIN		
FB	FLOWER BED		
FBR	FOOTBRIDGE		
FP	FOOTPATH		
PLF	PLATFORM		
PND	POND		
IC	INSPECTION COVER		
IL	INVERT LEVEL		
RCP	REFUSE COLLECTION POINT		
SHR	SHRINE		
SO	SOFFIT LEVEL		
TS	TEMPORARY STRUCTURE		
UC	U CHANNEL		
WIP	WORKS IN PROGRESS		
BS	BOUNDARY STONE		
E	ELECTRIC POLE		
FH	FIRE HYDRANT		
G	GATE		
GR	GRATING		
L	LAMP POST		
M	MANHOLE / MANHOLE FOUL		
MS	MANHOLE STORM		
M	MANHOLE TELEPHONE		
W	MANHOLE WATERWORKS		
PZ	PIEZOMETER TUBE		
SP	PARKING METER POST		
SP	SIGN POLE		
SB	SIGN BOARD		
SH	SHRINE		
TP	TELEPHONE POLE		
TK	TELEPHONE KIOSK		
TL	TRAFFIC LIGHT		
LB	LIGHT BOX		
TL	TRAFFIC LIGHT CONTROL BOX		
T	TREE		
UC	UTILITY CONTROL BOX		
G	GULLY		
V	VALVE FIRE		
V	VALVE GAS		
V	VALVE WATERWORKS		
W	WATER TAP		

SCALE 1 : 200 (Size A1)

DATE OF SURVEY : JUNE 2021

NOTE :-

- 1) ALL SPOT LEVEL POSITIONS ARE INDICATED BY A CROSS.
- 2) ALL GRID LINES ARE IN HONG KONG 1980 PRINCIPAL DATUM
- 3) ALL UNITS ARE IN METRES

CHYNCHEN ASSOCIATES LIMITED
CHARTERED LAND SURVEYORS

Lots 399RP(part) and 404 in DD121
Tai Tao Tsuen, Hung Shui Kiu, Yuen Long

TOPOGRAPHIC AND BOUNDARY SURVEY

REVISION NO.	DESCRIPTION	DATE	APPROVED BY:

PLAN NO. 3761/01

DRAWN BY: KEVIN
CHECKED BY: WING LAM
APPROVED BY:

NO. 142 HING HENRY WING WING APPLD 43

APPENDIX 1

Hydraulic Calculations

Assessment of Hydraulic Capacities of the Drainage System for 1 in 200 year design return period

Using Rational Method

Design Flow = $0.278CIA \text{ m}^3/\text{s}$ for grassland (heavy soil) - steep, C = 0.35
for concrete surface, C = 0.95

Using Manning Equation

Design Mean Velocity = $R^{1/6}/n(RS)^{1/2}$ and n = 0.013 for concrete pipe with good surface

Using Gumbel Solution in frequency analysis

Rainfall intensity = $a / (t_d + b)^c$ where a = 429.5, b = 2.05 and c = 0.295 in 200 year design return period
referenced to Table 3a – 'Storm Constants for Different Return Periods of HKO Headquarters' in SDM

Using Brandsby William's Equation (for channel flow)

Inlet time t_0 = $0.14465L / (H^{0.2}A^{0.1})$ or 2 when the distance is too short

Inlet time t_0 to Point Z = $[0.14465 \times 370] / \{[(133.30 - 20.90) / 370 \times 100]^{0.2} \times 46237\} = 9.24$
for Sub-Catchment 1 = 46,237 m²

Parameters Input

k_s (mm) = 0.6 k_s (m) = 0.0006
 v (m²/s) = 1.00E-06
 g (m²/s) = 9.81

(*allow minimum 500mm free board at the design section of U channels to allow for catchpit/manhole cover flushing with ground level)

USCP/USMH	DSCP/DSMH	USGL	DSGL	USIL	DSIL	INVERT DIFF.	LENGTH (m)	SLOPE s	SLOPE 1 IN	t_0 (min)	$t_c (= t_d)$ (min)	RAINFALL INTENSITY (mm/hr)	RAINFALL INTENSITY INCLUDING EFFECT OF CLIMATE CHANGE (+13.8%) (mm/hr)	RUNOFF COEF. C	SUB-CATCHMENT AREA (m ²)	EFF. AREA (m ²)	CUM. EFF. AREA (m ²)	DESIGN FLOW (m ³ /s)	SIZE (mm)	UC Type	VEL (m/s)	*FLOW CAPACITY (m ³ /s)	90% FLOW CAPACITY (for pipe) (m ³ /s)	SPARE CAPACITY (m ³ /s)	Occupancy of the proposed channel / pipe								
Within the Subject Site																																	
Sub-catchment Area 4	Point B										2.00			0.95	500	475	475																
Point B	CP2.1	11.79	11.79	10.99	10.91	0.09	8.50	0.010	100	2.00	2.08	282.59	321.59	0.95	899	854	1,329	0.119	300	UC	1.70	0.14		0.018	87%	OK!							
CP2.1	CP2.2	11.79	11.56	10.91	10.50	0.41	41.00	0.010	100	2.08	2.48	274.97	312.92	0.95	0	0	1,329	0.116	300	UC	1.70	0.14		0.021	84%	OK!							
CP2.2	CP2.3	11.56	11.65	10.50	10.40	0.10	10.00	0.010	100	2.48	2.58	273.25	310.95	0.95	0	0	1,329	0.115	300	UC	1.70	0.14		0.022	84%	OK!							
CP2.3	CP2.4	11.65	11.69	10.40	10.32	0.08	8.00	0.010	100	2.08	2.16	281.03	319.81	0.95	0	0	1,329	0.118	300	UC	1.70	0.14		0.019	86%	OK!							
CP2.4	CP2.5	11.69	11.48	10.32	10.26	0.06	5.50	0.010	100	2.48	2.54	274.02	311.83	0.95	0	0	1,329	0.115	300	UC	1.70	0.14		0.022	84%	OK!							
CP2.5	CP2.6	11.48	11.20	10.26	10.15	0.12	11.50	0.010	100	2.48	2.60	272.99	310.66	0.95	0	0	1,329	0.115	300	UC	1.70	0.14		0.022	84%	OK!							
CP2.6	CP2.7	11.20	11.47	10.15	10.11	0.04	4.00	0.010	100	2.58	2.62	272.57	310.18	0.95	0	0	1,329	0.115	300	UC	1.70	0.14		0.022	84%	OK!							
CP2.7	TM	11.47	11.32	10.11	9.97	0.14	14.00	0.010	100	2.58	2.72	270.91	308.29	0.95	0	0	1,329	0.114	300	UC	1.70	0.14		0.023	83%	OK!							
Point A	CP1.1	11.75	11.70	10.95	10.59	0.36	36.00	0.010	100	2.00	2.35	277.38	315.66	0.95	899	854	854	0.075	300	UC	1.70	0.14		0.062	55%	OK!							
CP1.1	CP1.2	11.70	11.64	10.59	10.32	0.27	27.00	0.010	100	2.35	2.62	272.65	310.28	0.95	0	0	854	0.074	300	UC	1.70	0.14		0.063	54%	OK!							
CP1.2	CP1.3	11.64	11.42	10.32	10.00	0.32	32.00	0.010	100	2.62	2.93	267.48	304.39	0.95	0	0	854	0.072	300	UC	1.70	0.14		0.065	53%	OK!							
CP1.3	TM	11.42	11.32	10.00	9.87	0.13	13.00	0.010	100	2.62	2.74	270.50	307.83	0.95	0	0	854	0.073	300	UC	1.70	0.14		0.064	53%	OK!							
External Drainage (between the Subject Site and Outfall)																																	
TM	Existing external Catchpit 1	11.32	11.50	9.87	9.85	0.02	2.00	0.010	100	0.00	2.76	270.23	307.52	0.95	0	0	2,183	0.187	450	concreted pipe	2.03	0.32	0.29	0.104	64%	OK!							
Existing external Catchpit 1	Existing external Catchpit 2	11.50	11.56	9.65	9.42	0.23	23.00	0.010	100	0.00	2.95	267.18	304.05	0.95	373	354	2,537	0.214	450	concreted pipe	2.03	0.32	0.29	0.077	74%	OK!							
Existing external Catchpit 2	Existing Outlet	11.56	11.69	9.15	9.10	0.05	15.00	0.003	300	0.00	3.14	264.19	300.65	0.95	0	0	2,537	0.212	525	concreted pipe	1.29	0.28	0.25	0.039	85%	OK!							
The Existing 2000mm x 2000mm Box Culvert																																	
highest point	Point Z	133.30	20.90				370.00			9.24	9.24			0.35	46,237	16,183	16,183																
Point Z	Point Y	20.90	11.69	18.90	9.10	0.90	450.00	0.002	500	9.24	12.09	196.58	217.03	0.95	60,521	57,495	73,678	4.445	2000	box culvert	2.63	10.50		6.056	42%	OK!							
															total =	106,758																	

Sub-Catchment Area 1 = 46,237
Sub-Catchment Area 2 = 57,850
Sub-Catchment Area 3 = 373
Sub-Catchment Area 4 = 500
Area of The Site = 1,798

Total = 106,758 m²

APPENDIX 2

**Copy of the Final Sewerage Impact Assessment (SIA) Report
submitted in support of the planning application in March 2018**

By Hand

The Secretary
Town Planning Board
15/F, North Point Government Offices
333 Java Road
North Point, Hong Kong

12 March 2018

Dear Sir/Madam

**Application for Permission
Under Section 16 of the Town Planning Ordinance (Cap.131)
Lot Nos. 398RP (Part) and 404 in D.D.121, Tai Tao Tsuen
Hung Shui Kiu, Yuen Long, New Territories**

(Application No. A/YL-TYST/870)

Submission of Further Information

Thank you for your letter dated 26 January 2018 acknowledging our request for deferral of the consideration of the captioned S16 Planning Application for a period of 2 months.

We are pleased to submit Further Information on the captioned application. Please see attached our Responses to Comments Table (**Appendix A**), a proposed road widening scheme for the Application Site (**Appendix B**), updated Master Layout Plan and Architectural Drawings for the Proposed Development (**Appendix C**), updated Environmental Assessment Report (**Appendix D**), Sewerage Impact Assessment (**Appendix E**), a Technical Paper of traffic forecast for Traffic Noise Impact Assessment (**Appendix F**), a design intent in window opening and orientation (**Appendix G**), an updated Visual Impact Assessment (**Appendix H**), updated Landscape Master Plan and open space provision (**Appendix I**) and pedestrian route for Application Site (**Appendix J**) for your consideration.

We sincerely seek for the favourable consideration from the Town Planning Board to approve this S12A Planning Application.

Should you have any queries, please contact the undersigned or our Ms Minnie Law at [REDACTED]

Yours faithfully

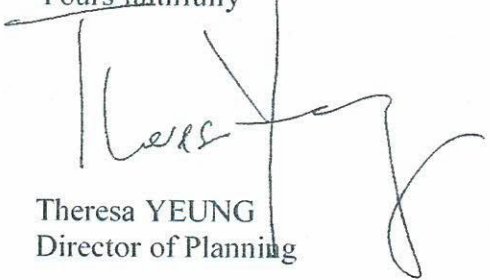
Theresa YEUNG
Director of Planning

Encl. Appendices A - J
c.c. DPO/TM&YLW, PlanD (Attn: Mr. Floria Tsang (Fax: 2489 9711))
Client

Orient Talent Limited

**Sewerage Impact Assessment for
Proposed Residential Care Home
for the Elderly, Hung Shui Kiu,
Yuen Long, N.T**

Final Sewerage Impact Assessment Report

256020-REP-001-01

Rev 01 | March 2018

This report takes into account the particular instructions and requirements of our client.

It is not intended for and should not be relied upon by any third party and no responsibility is undertaken to any third party.

Job number 256020

Ove Arup & Partners Ltd

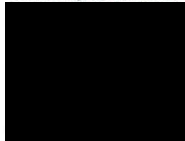

ARUP

Contents

	Page
1 Introduction	1
1.1 Background	1
1.2 Proposed Development	1
1.3 Purpose of this Report	2
2 Sewerage Impact Assessment	3
2.1 Methodology and Design Criteria	3
2.2 Existing Sewerage System	5
2.3 Sewage Flow Estimation	5
2.4 Proposed Sewerage Provision	7
2.5 Potential Sewerage Impacts	7
3 Summary and Conclusion	9

Appendices

Appendix A

Drawings for Existing and Proposed Sewerage Layout Plan

Appendix B

Sewage Flow Estimation for Proposed Development and Existing Sewerage Catchment

Appendix C

Capacity Performance of the Proposed DN225 Sewers and the Existing DN375 Sewers

1 Introduction

1.1 Background

1.1.1 Orient Talent Limited appointed Ove Arup and Partners (HK) Ltd to undertake a Sewerage Impact Assessment (SIA) of the Proposed Residential Care Home for the Elderly development at Lot nos. 398RP (Part) and 404 in D.D. 121, Hung Shui Kiu, Yuen Long, New Territories (Proposed Development).

1.2 Proposed Development

1.2.1 The study area of Proposed Development is about 1,795m². It is located at Lot Nos. 398RP (Part) and 404 in D.D. 121, Hung Shui Kiu, Yuen Long, N.T. The site is currently used as an open storage and rural workshop. It falls within a small portion of the “Comprehensive Development Area” (“CDA”) on the Draft Tong Yan San Tsuen Outline Zoning Plan No. S/YL-TYST/11. The study area is shown in Figure 1.1.

Figure 1.1 Location Plan of Study Area with OZP Zoning

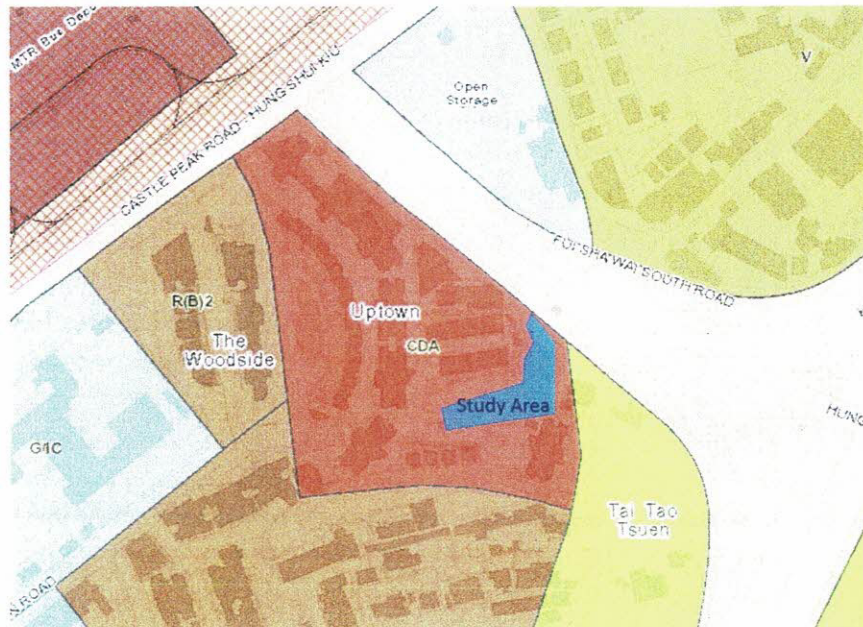

1.2.2 The Proposed development will be a Residential Care Home for the Elderly (RCHE). The development parameters for the Proposed Development are summarized in Table 1.1 below.

Table 1.1 Proposed Development Parameters

Parameter	Remark
Site Area	About 1,795 m ²
Plot Ratio (PR)	Not more than 2.96 #

Parameter	Remark
Gross Floor Area (GFA)	Not more than 5,313 m ²
No. of beds	About 300
Local Open Space Provision *	Not less than 300 m ²

Note:

* According to the Hong Kong Planning Standards and Guidelines (HKPSG), there is no requirement for RCHE, as a social welfare facility, on active and passive recreational use. Notwithstanding, the Proposed Development will provide not less than 300m² open space for the occupants, which respects the standard of 3.

The subject "CDA" zone has an area of 23,282 m². According to the Notes of Outline Zoning Plan (OZP), a maximum GFA of 69,000m² is allowed. Therefore, a PR of 2.96 is adopted for the Application Site, assuming GFA is distributed evenly within the "CDA" zone.

1.3 Purpose of this Report

1.3.1

This SIA Report will assess the sewerage impacts, if any, that arise from the development of the lot and provide recommendations for mitigation measures and sewage connection proposals for the Proposed Development.

2 Sewerage Impact Assessment

2.1 Methodology and Design Criteria

2.1.1 The sewage flow estimation, assessment and evaluation of impacts are based on the following established principals, guidelines and record plans of Hong Kong:

- Guidelines for Estimating Sewage Flows for Sewage Infrastructure (GESF), Environmental Protection Department (EPD);
- Hong Kong Planning Standards and Guidelines (HKPSG), Planning Department (PlanD);
- Sewerage Manual, Drainage Services Department (DSD);
- Commercial and Industrial Floor Space Utilization Survey (CIFSUS), PlanD; and
- Sewerage Record Plans based on GeoInfo Map online

Unit Flow Factor – Domestic Flows

2.1.2 Unit flow factor (UFF) used for domestic sewage flow estimation of residential population in the sewerage catchment adjacent to the Proposed Development is shown in **Table 2.1** below.

Table 2.1 Unit Flow Factor for Domestic Flows

Residential Type	Unit Flow Factor (m ³ /person/day) ¹¹
Private R2	0.270

Note:

¹¹ Table T-1, GESF

Unit Flow Factors - Commercial and Institutional Flows

2.1.3 The unit flow factors for commercial flows due to employed population of the proposed social welfare facility for the Elderly is shown in **Table 2.2**.

Table 2.2 Unit Flow Factor for Commercial Flows

Commercial Type	Unit Flow Factor (m ³ /employee/day) ¹¹
Commercial Employee	0.080
Commercial Activities	
(a) Specific trades:	
J11 – Community, Social and Personal Services	0.200 ¹²
Total UFF	0.280

Notes:

¹¹ Table T-2, GESF

¹² UFF for J11 accounts for flows of customers and tenants

2.1.4 The total unit flow generated from an employee in a particular trade is the sum of the unit flow factor of the employee and the unit flow factor of commercial activities of a particular trade under consideration.

Peaking Factors

2.1.5 The peaking factors adopted in this study are shown in **Table 2.3**.

Table 2.3 Peaking Factors for Various Population Ranges

Population Range ^[1]	Peaking Factor (including stormwater allowance) for Facility with Existing Upstream Sewerage ^[2]
(a) For sewers	
< 1,000	8
1,000 – 5,000	6

Note:

^[1] Contributing Population = Calculated total average flow (m³/day) / 0.27 (m³/person/day)

^[2] Table T-5, GESF

2.1.6 Under normal condition, peaking factors (excluding stormwater allowance) are applicable to planning sewerage facilities receiving flow from new upstream sewerage systems which essentially have no misconnections and defects for infiltration while the peaking factor (including stormwater allowance) are applicable to aged sewerage facilities with some misconnections and defects for infiltration. In order to be conservative in this analysis and allowing for future potential storm water infiltration due to degradation of pipe material after many years, peaking factors (including stormwater allowance) is adopted for both Proposed Development and existing development.

Hydraulic Analysis

2.1.7 Colebrook-White equation is applied for pipe hydraulic analysis. The design roughness coefficients (Ks) for existing pipeline system is 3.0mm (Slimed sewer, clayware, under poor condition). The design roughness coefficients (Ks) for proposed pipeline system is also 3.0mm in consideration of its reduced hydraulic performance in future due to degradation of material.

2.1.8 For small diameter sewers of diameter less than 300mm, the flow velocity of at least 0.7m/s shall occur daily, or that a gradient of at least 1:DN (i.e. Nominal diameter of the sewer in mm) is provided, provided that a flow of 2 times of Average Dry Weather Flow (ADWF) is assumed to occur at least once daily. For larger diameter sewers of diameter up to 900mm, a self-cleansing velocity of 1.0m/s in full pipe condition shall be achieved. The maximum flow velocity at peak flow shall be 3m/s.

2.2 Existing Sewerage System

2.2.1 The sewerage records were extracted from free online source GeoInfo Map which show the existing sewerage network in the vicinity of study area (**Figure 2.1**). There are an existing DN375 sewer running along the Castle Peak Road (Hung Shui Kiu) from northeast to southwest and another DN225 to DN450 sewer running along the Hung Shun Road from northeast to southwest and turning to north at junction of Ying Fuk Street and Hung Shun Road. Both sewers combined near junction of Castle Peak Road (Hung Shui Kiu) and Tan Kwai Tsuen Road and enlarged to be DN750.

Figure 2.1 Existing Sewerage Record Plan

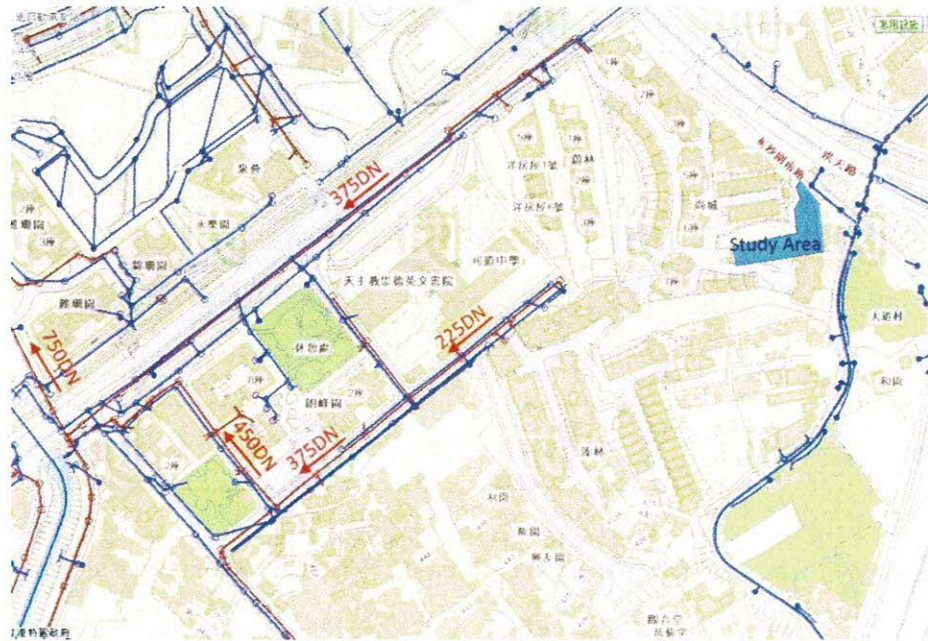

2.3 Sewage Flow Estimation

2.3.1 The maximum employees in the Proposed Development is estimated to be 176 based on the worker density with reference to the PlanD's CIFSUS and the maximum GFA of Proposed Development.

Table 2.4 Estimation of Employee in the Proposed Development

GFA(m ²)	Industry Group ^[1]	Worker Density (No of Employee / 100 m ² GFA) ^[1]	No of Employee
5,313	Community, Social & Personal Services	3.3	176

Note:

^[1] With reference to Figure 9 "Worker Density by Industry Group" of the PlanD's CIFSUS

2.3.2 With reference to EPD's GESF, the UFF for the Proposed Development is 0.28 m³/day/person according to **Table 2.2** and peaking factor of 8 is

adopted according to **Table 2.3**. Therefore, sewage flow estimation for the Proposed Development is shown in **Table 2.5** below.

Table 2.5 Sewage Flow Estimation of the Proposed Development

No of Employee	UFF (m ³ /day/person)	ADWF (m ³ /day)	Peaking Factor	Peak Flow (l/s)
176	0.28	49.28	8	4.56

2.3.3

There are two major Contribution Sewerage Catchments, private residential development of Uptown and the Woodside, for the existing DN375 sewer along Castle Peak Road (Hung Shui Kiu). The population of Uptown and the Woodside is estimated based on the total number of flats of the developments and the average household size with reference to "Hong Kong Domestic Household Projections up to 2051" from Census and Statistics Department(C&SD), which is shown in **Table 2.6** below.

Table 2.6 Estimation of Population in the Existing Contributing Sewerage Catchments

Contributing Sewerage Catchment	No of Flat	Person per Flat (PPF) ^[1]	No. of Residents
Uptown	734	2.8	2,055
The Woodside	98	2.8	274

Note:

^[1] With reference to "Table 2: Number of domestic households and average household size" from "Hong Kong Domestic Household Projections up to 2051", C&SD

2.3.4

With reference to EPD's GESF, the UFF for the domestic flow from the existing sewerage catchments is 0.27 m³/day/person according to **Table 2.1** and peaking factor is adopted according to **Table 2.3**. Therefore, sewage flow estimation for the existing contributing sewerage catchments is shown in **Table 2.7** below.

Table 2.7 Sewage Flow Estimation of the Existing Contributing Sewerage Catchment

Contributing Sewerage Catchment	No. of Residents	UFF (m ³ /day/person)	ADWF (m ³ /day)	Peaking Factor	Peak Flow (l/s)
Uptown	2,055	0.27	554.90	6	38.54
The Woodside	274	0.27	74.09	8	6.86

2.4 Proposed Sewerage Provision

Sewerage Connection Proposal

2.4.1 A new DN225 sewer is proposed to run along the Fui Sha Wai South Road from southeast to northwest, and turning into Castle Peak Road (Hung Shui Kiu) running from northeast to southwest along the footpath. The proposed alignment is shown in **Appendix A**.

Internal Development Sewerage System

2.4.2 New internal sewerage systems will be provided within the Proposed Development that will convey the sewage to the proposed manhole HSK-01 shown in **Appendix A**.

2.5 Potential Sewerage Impacts

2.5.1 There are three incoming sewage flow for the existing DN375 sewer after the proposed sewer connection: (i) the existing sewerage connection at manhole FMH1036685 for Uptown; (ii) existing sewerage connections at manhole FMH1043120 and FMH1036687 for the Woodside; and (iii) the proposed sewerage connection at manhole HSK-01 for the Proposed Development. Total estimated sewage flow for those connections is shown Table B3 in **Appendix B**.

2.5.2 Hydraulic calculation (attached in **Appendix C**) has been carried out to assess the capacity of the proposed and existing sewer capacities under the estimated peak flow (Table B3 of the **Appendix B**).

2.5.3 Results of the hydraulic calculation (**Appendix C**) demonstrated that the proposed sewerage provision, comprising the new gravity sewers of DN225 with approximate length of 235m, is adequate to serve the Proposed Development. **Table 2.8** summaries the key results of the hydraulic capacity assessment for the proposed DN225 sewer.

Table 2.8 Hydraulic Capacity of the Proposed DN225 Sewer

Upstream Manhole ID	Downstream Manhole ID	Sewer Length (m)	Peak Flow (l/s)	Sewer Hydraulic Capacity (l/s)	% of Peak Flow over Sewer Hydraulic Capacity
HSK-01	HSK-02	46.7	4.56	54.564	8%
HSK-02	HSK-03	45.6	4.56	43.485	10%
HSK-03	HSK-04	30.6	4.56	30.343	15%
HSK-04	HSK-05	47.4	4.56	30.343	15%
HSK-05	HSK-06	32.5	4.56	30.343	15%
HSK-06	FMH1036685	31.4	4.56	30.343	15%

2.5.4 Results of the hydraulic calculation (**Appendix C**) also indicated that the total peak sewage flow from the Proposed Development and from

existing sewerage catchments is less than 50% of the fullbore capacity of the existing DN375 sewer along the Castle Peak Road – Hung Shui Kiu. Therefore, the existing DN375 sewer at immediate downstream of the Proposed Development has adequate capacity to serve both the existing development and Proposed Development and it deems that no adverse sewerage impacts is anticipated on the existing sewerage network due to the Proposed Development. **Table 2.9** summaries the key results of the hydraulic capacity assessment for the existing DN375 sewer.

Table 2.9 Hydraulic Capacity of the Existing DN375 Sewer

Upstream Manhole ID	Downstream Manhole ID	Sewer Length (m)	Peak Flow (l/s)	Sewer Hydraulic Capacity (l/s)	% of Peak Flow over Sewer Hydraulic Capacity
FMH1036685	FMH1043120	41.7	41.96	87.701	48%
FMH1043120	FMH1036686	3.2	44.53	156.419	28%
FMH1036686	FMH1036687	19.1	44.53	106.953	42%
FMH1036687	FMH1036688	41.7	47.10	221.184	21%
FMH1036688	FMH1036689	3.2	47.10	199.580	24%
FMH1036689	FMH1036690	41.2	47.10	95.284	49%
FMH1036690	FMH1036691	39.2	47.10	101.711	46%
FMH1036691	FMH1036692	20.9	47.10	115.981	41%
FMH1036692	FMH1036693	41.5	47.10	94.937	50%
FMH1036693	FMH1036694	39.7	47.10	101.065	47%
FMH1036694	FMH1036695	40.5	47.10	96.109	49%
FMH1036695	FMH1036696	18.3	47.10	101.129	47%
FMH1036696	FMH1036697	37.1	47.10	104.566	45%
FMH1036697	FMH1036698	34.7	47.10	112.245	42%
FMH1036698	FMH1032220	11.7	47.10	283.848	17%

3 Summary and Conclusion

- 3.1.1 The peak sewage flow from the Proposed Development is estimated to be 4.56l/s.
- 3.1.2 As the nearest sewer network is not directly adjacent to the development, a new DN225 sewer is proposed to run along the Fui Sha Wai South Road from southeast to northwest, and turning into Castle Peak Road (Hung Shui Kiu) running from northeast to southwest along the footpath, to convey the sewage from the development site to the existing DN375 sewer along Castle Peak Road (Hung Shui Kiu).
- 3.1.3 Hydraulic assessment indicates that the existing DN375 sewer running along the Castle Peak Road (Hung Shui Kiu) at immediate downstream of the Proposed Development has adequate capacity to serve both the existing and Proposed Development. Therefore, no adverse sewerage impacts are anticipated due to the Proposed Development.

Appendix A

Drawings for Existing and Proposed Sewerage Layout Plan

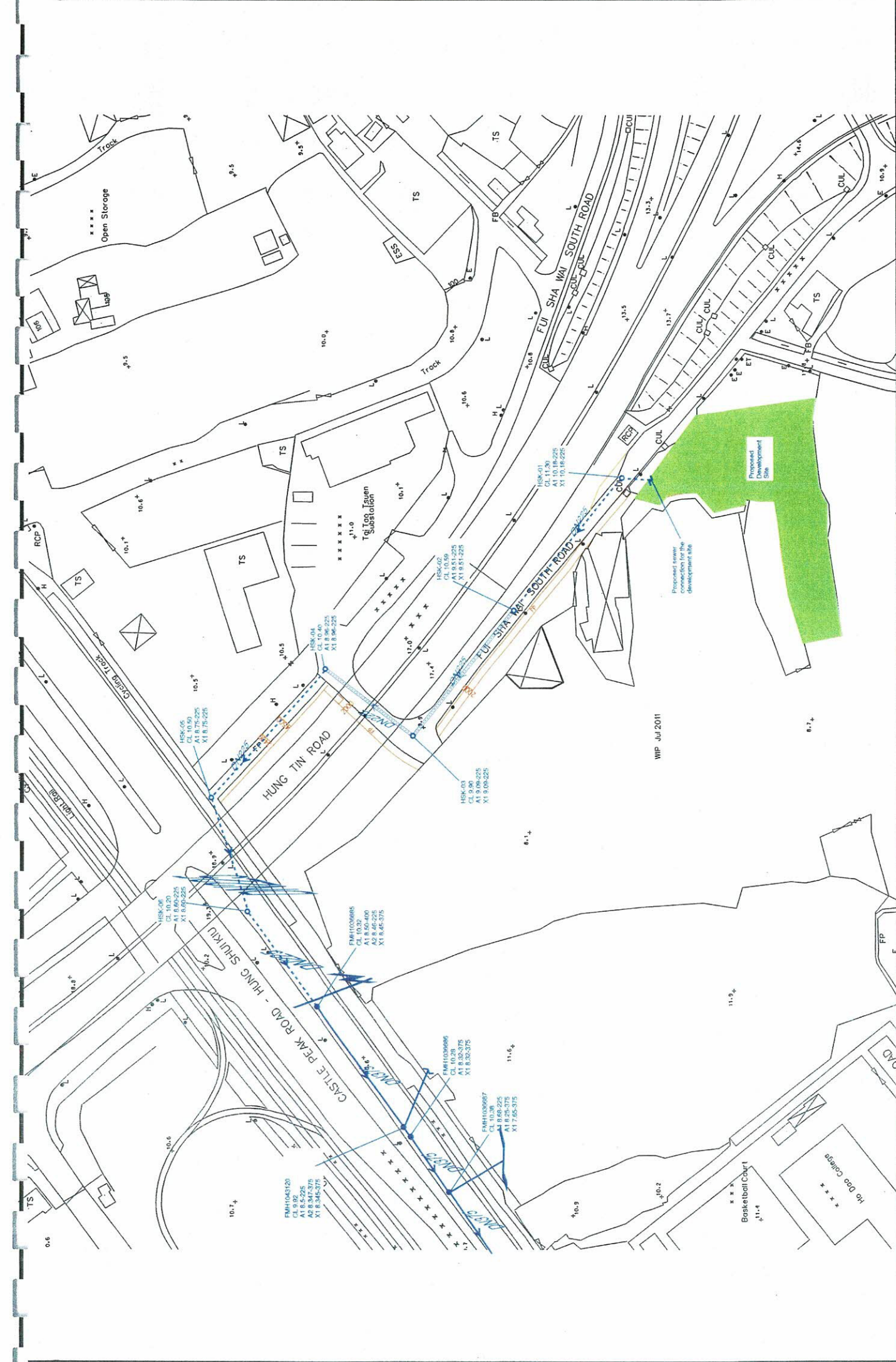

Legend:
 Existing Sewer Mainhole and Pipes
 Proposed Sewer Mainhole and Pipes
 Proposed Sewer Mainhole and Pipes
 With Concrete Surround

Drawing Title
 EXISTING AND PROPOSED
 SEWERAGE LAYOUT PLAN

Project Title
 SEWERAGE IMPACT ASSESSMENT FOR
 PROPOSED RESIDENTIAL CARE HOME FOR THE
 ELDERLY, HUNG SHUI KIU, YUEN LONG, N.T

W/P Jul 2011

Appendix B

Sewage Flow Estimation for Proposed Development and Existing Sewerage Catchment

Sewerage Impact Assessment for Proposed Residential Care Home for the Elderly, Hung Shui Kiu, Yuen Long, N.T

Appendix B

Sewage Flow Estimation for Proposed Development and Existing Sewerage Catchment

Table B1 Sewage Flow Estimation of the Proposed Development

Contributing Sewerage Catchment	GFA (m ²)	Woker Density (per 100 m ² GFA) ⁽¹⁾	No of Employee	UFF (m ³ /day)	ADWF (m ³ /day)	Peaking Factor	Peak Flow (l/s)
The proposed development	5313	3.3	176	0.28	49.28	8	4.56

Note:

(1) According to Figure 9 of PlanD's CIFSUS

Table B2 Sewage Flow Estimation of the Existing Contributing Sewerage Catchment

Contributing Sewerage Catchment	No of Flat	Person per Flat (PPF) ⁽¹⁾	No of Residents	UFF (m ³ /day)	ADWF (m ³ /day)	Peaking Factor	Peak Flow (l/s)
Uptown	734	2.8	2055	0.27	554.90	6	38.54
The Woodside	98	2.8	274	0.27	74.09	8	6.86

Note:

(1) According to "Table 2: Number of domestic households and average household size" from "Hong Kong Domestic Household Projections up to 2051", C&SD

Table B3 Total Existing Sewage Flow to Discharging to DN375 along the Castle Peak Road - Hung Shui Kiu after the Proposed Development

Contributing Sewerage Catchment	No of Employee/ Residents	Connecting Manhole ID	ADWF (m ³ /day)	Total Accumulative ADWF (m ³ /day)	Total Contribution Population	Peaking Factor	Total Peak Flow (l/s)
The proposed development	176	HSK-01	49.28	49	183	8	4.56
Uptown	2055	FMH1036685	554.90	604	2238	6	41.96
Half of the Woodside ⁽¹⁾	137	FMH1043120	37.04	641	2375	6	44.53
Half of the Woodside ⁽¹⁾	137	FMH1036687	37.04	678	2512	6	47.10

Note:

(1) Assume half of the sewage flow from the Woodside will be discharged to FMH1043120 while the remaining half would be discharge to FMH1036687 (Refer to Appendix C for detail)

Appendix C

Capacity Performance of the Proposed DN225 Sewers and the Existing DN375 Sewers

Sewerage Impact Assessment for Proposed Residential Care Home for the Elderly, Hung Shui Kiu, Yuen Long, N.T

Appendix C

Capacity Performance of the Proposed DN 225 Sewers and the Existing DN375 Sewers

US MHNo.	DS MHNo.	Length (m)	Number of Pipe	Pipe Diameter (mm)	US GL (mMSL)	DS GL (mMSL)	US IL (mMSL)	DS IL (mMSL)	Gradient	Gradient (1 in X)	Area (m ²)	Perimeter (m)	R=A/P (m)	(32gRS) ^{0.5}	Velocity at full bore (m/s)	Total Peak Flow ⁽¹⁾ (L/s)	Velocity Check	Capacity (L/s)	% Full Flow
HSK-01	HSK-02	46.7	1	225	11.30	10.59	10.18	9.51	0.0143	70	0.0397	0.7	0.06	0.50	1.37	4.56	OK	54.564	8%
HSK-02	HSK-03	45.6	1	225	10.59	9.90	9.51	9.09	0.0091	110	0.0397	0.7	0.06	0.40	1.09	4.56	OK	43.485	10%
HSK-03	HSK-04	30.6	1	225	9.9	10.4	9.09	8.96	0.0044	225	0.0397	0.7	0.06	0.28	0.76	4.56	OK	30.343	15%
HSK-04	HSK-05	47.4	1	225	10.4	10.5	8.96	8.75	0.0044	225	0.0397	0.7	0.06	0.28	0.76	4.56	OK	30.343	15%
HSK-05	HSK-06	32.5	1	225	10.5	10.2	8.75	8.60	0.0044	225	0.0397	0.7	0.06	0.28	0.76	4.56	OK	30.343	15%
FMH1036685	FMH1036685	31.4	1	225	10.2	10.3	8.60	8.46	0.0025	405	0.0397	0.7	0.06	0.27	0.79	41.96	OK	30.343	15%
FMH1043120	FMH1043120	41.7	1	375	10.3	9.9	8.45	8.35	0.0025	405	0.1104	1.2	0.09	0.27	0.79	41.96	OK	87.701	48%
FMH1036686	FMH1036686	3.2	1	375	9.9	10.3	8.35	8.32	0.0078	128	0.1104	1.2	0.09	0.48	1.42	44.53	OK	156.419	28%
FMH1036687	FMH1036687	19.1	1	375	10.3	10.4	8.32	8.25	0.0037	273	0.1104	1.2	0.09	0.33	0.97	44.53	OK	106.953	42%
FMH1036688	FMH1036688	41.7	1	375	10.4	10.8	7.65	7.00	0.0156	64	0.1104	1.2	0.09	0.68	2.00	47.10	OK	221.184	21%
FMH1036689	FMH1036689	3.2	1	375	10.8	10.6	6.40	6.36	0.0127	79	0.1104	1.2	0.09	0.61	1.81	47.10	OK	199.580	24%
FMH1036690	FMH1036690	41.2	1	375	10.6	10.9	6.36	6.24	0.0029	343	0.1104	1.2	0.09	0.29	0.86	47.10	OK	95.284	49%
FMH1036691	FMH1036691	39.2	1	375	10.9	11.0	6.24	6.11	0.0033	302	0.1104	1.2	0.09	0.31	0.92	47.10	OK	101.711	46%
FMH1036692	FMH1036692	20.9	1	375	11.0	10.9	6.11	6.02	0.0043	232	0.1104	1.2	0.09	0.36	1.05	47.10	OK	115.981	41%
FMH1036693	FMH1036693	41.5	1	375	10.9	10.9	6.02	5.90	0.0029	346	0.1104	1.2	0.09	0.29	0.86	47.10	OK	94.937	50%
FMH1036694	FMH1036694	39.7	1	375	10.9	10.8	5.90	5.77	0.0033	305	0.1104	1.2	0.09	0.31	0.92	47.10	OK	101.065	47%
FMH1036695	FMH1036695	40.5	1	375	10.8	10.9	5.77	5.65	0.0030	338	0.1104	1.2	0.09	0.30	0.87	47.10	OK	96.109	49%
FMH1036696	FMH1036696	18.3	1	375	10.9	11.0	5.65	5.59	0.0033	305	0.1104	1.2	0.09	0.31	0.92	47.10	OK	101.129	47%
FMH1036697	FMH1036697	37.1	1	375	11.0	10.9	5.59	5.46	0.0035	285	0.1104	1.2	0.09	0.32	0.95	47.10	OK	104.566	45%
FMH1036698	FMH1036698	34.7	1	375	10.9	10.9	5.46	5.32	0.0040	248	0.1104	1.2	0.09	0.34	1.02	47.10	OK	112.245	42%
FMH1036698	FMH1032220	11.7	1	375	10.9	11.0	5.32	5.02	0.0256	39	0.1104	1.2	0.09	0.87	2.57	47.10	OK	283.848	17%

Note:

(1) Refer to Table B3 of the Appendix B for the Total Peak Flow Estimation

Appendix 3 - Hydraulic Analysis of Relevant Sewers

Assessment of Hydraulic Capacities of Sewers under Peak Flows

Using Colebrook's White Equation (for pipe flow)

$$V = - \text{Sqrt} (8gDs) \times \log [k_s / 3.7D + 2.51v / (D \times \text{Sqrt} (2gDs))]$$

For precast concrete pipes with 'O' ring joints with poor condition,

$$k_s \text{ (mm)} = 3 \quad k_s \text{ (m)} = 0.003$$

$$v \text{ (m}^2\text{/s)} = 1.00\text{E-}06$$

$$g \text{ (m}^2\text{/s)} = 9.81$$

USCP/USMH	DSCP/DSMH		USGL	DSGL	USIL	DSIL	INVERT DIFF.	LENGTH (m)	SLOPE s	SLOPE 1 IN	PEAK DESIGN FLOW (l/s)	SIZE (mm)	Drain Type	VEL (m/s)	FLOW CAPACITY (l/s)	90% FLOW CAPACITY (for pipe) (l ³ /s)	SPARE CAPACITY (l ³ /s)	OCCUPANCY OF THE PROPOSED DRAIN	
External Drainage (between the Subject Site and Existing Public Sewer) (Peaking Factor = 8)																			
Sewer TM (D.T.L.)	HSK-01	The subject development	11.20	10.83	10.32	10.18	0.14	11.00	0.013	79	18.770	225	concrete drain	1.16	45.947	41.353	22.583	45%	OK!
HSK-01	HSK-02	Ditto	10.83	10.59	10.18	9.51	0.67	49.00	0.014	73	18.770	225	concrete drain	1.20	47.629	42.866	24.096	44%	OK!
HSK-02	HSK-03	Ditto	10.59	10.20	9.51	9.09	0.42	48.00	0.009	114	18.770	225	concrete drain	0.96	38.080	34.272	15.502	55%	OK!
HSK-03	HSK-04	Ditto	10.20	10.30	9.09	8.81	0.28	50.00	0.006	179	18.770	225	concrete drain	0.77	30.443	27.398	8.628	69%	OK!
HSK-04	HSK-05	Ditto	10.30	10.23	8.81	8.77	0.04	7.80	0.005	195	18.770	225	concrete drain	0.73	29.128	26.215	7.445	72%	OK!
HSK-05	HSK-06	Ditto	10.23	10.40	8.77	8.56	0.21	38.00	0.006	181	18.770	225	concrete drain	0.76	30.241	27.217	8.447	69%	OK!
The Existing Sewers along Castle Peak Road - Hung Shui Kiu (Peaking Factor = 6)																			
HSK-06	FMH1036685	The subject development + Uptown	10.40	10.32	8.56	8.46	0.10	8.00	0.013	80	52.618	400	concrete drain	1.68	211.663	190.496	137.879	28%	OK!
FMH1036685	FMH1043120	Ditto	10.32	9.92	8.45	8.35	0.10	41.70	0.002	417	52.618	375	concrete drain	0.71	77.904	70.114	17.496	75%	OK!
FMH1043120	FMH1036686	The subject development + Uptown + 0.5 x Woodside	9.92	10.28	8.35	8.32	0.03	3.20	0.009	107	55.190	375	concrete drain	1.40	154.319	138.887	83.697	40%	OK!
FMH1036686	FMH1036687	Ditto	10.28	10.38	8.32	8.25	0.07	19.10	0.004	273	55.190	375	concrete drain	0.87	96.377	86.739	31.549	64%	OK!
FMH1036687	FMH1036688	Ditto	10.38	10.77	7.65	7.00	0.65	41.70	0.016	64	55.190	375	concrete drain	1.80	199.071	179.164	123.974	31%	OK!
FMH1036688	FMH1036689	The subject development + Uptown + Woodside	10.77	10.64	6.40	6.36	0.04	3.20	0.013	80	57.763	375	concrete drain	1.61	178.237	160.414	102.651	36%	OK!
FMH1036689	FMH1036690	Ditto	10.64	10.92	6.36	6.24	0.12	41.20	0.003	343	57.763	375	concrete drain	0.78	85.886	77.297	19.535	75%	OK!
FMH1036690	FMH1036691	Ditto	10.92	11.00	6.24	6.11	0.13	39.20	0.003	302	57.763	375	concrete drain	0.83	91.664	82.498	24.735	70%	OK!

Peak Design Flows (l/s)
 The subject develop 18.77 (for Peaking Factor = 8)
 14.08 (for Peaking Factor = 6)
 Uptown 38.54 (for Peaking Factor = 6)
 Woodside 6.86 (for Peaking Factor = 8)
 5.15 (for Peaking Factor = 6)